

## SERIES 5000 TYPE 5011 / 5020 INFRA-RED FIRE & HEAT DETECTORS Conveyor & Transport System Monitoring



The Patol 5000 Series of equipment is specifically designed for the protection of establishments and systems where a movement of materials with a potential fire hazard is a routine occurrence.

The 5000 system employs enhanced Infra-red monitoring technology that enables the detection of fire initiating materials, whilst they are being transported, and before they have reached a Flame condition.

The system has many applications within industries such as Power Generation, Coal Mining, Process Plant, Road Transportation and Rail Networks and has been specifically designed to both meet the rigours of these environments and to provide the reliability required.

- ◆ **Detection of hazards at temperatures below flame point including both embers and buried hot spots.**
- ◆ **Air purged system for *Dusty* environments with air pressure monitoring.**
- ◆ **Eight high integrity detectors set as four channels for maximum reliability.**
- ◆ **Multi-facet lensing provides wide uniform coverage superior to some ember/spark detectors.**
- ◆ **Coincidence- *Double Knock* - option for unit detectors as standard.**
- ◆ **Special configurations and application specific calibration options.**
- ◆ **Timed auto reset / coincidence analyser circuit.**
- ◆ **Tuned response - solar blind.**
- ◆ **Specifically designed for high EMC compliance**

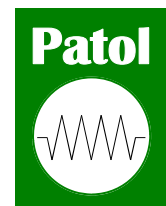

## TYPE 5011 / 5020 INFRA-RED FIRE & HEAT DETECTORS

### Principles

The principle of operation is that temperature dependent black body emissions occur for all materials. These emissions range through the infra red spectrum to visible light. Both the wavelength and level of peak energy emission are related to temperature.

The Series 5000 detectors are designed to detect the changes in these emissions that occur when a hot body enters the field of view of the detector.

By the use of both optical filtering and electronic analysis of the various parameters the system is blind to visible light from the sun or local luminaires, whilst being able to detect relatively low temperature material moving through the field of view.

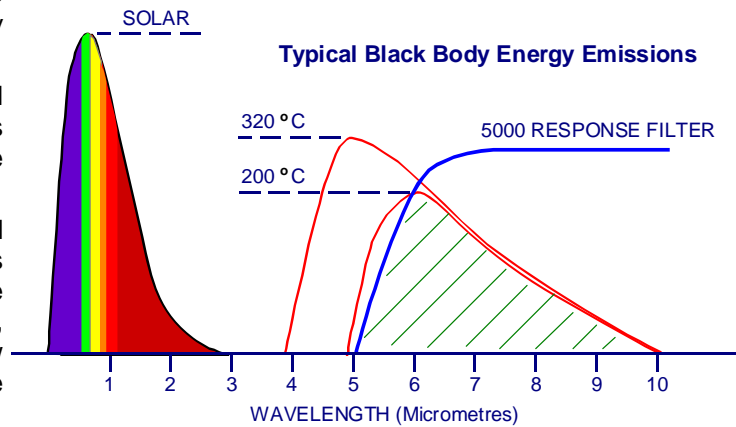

### Applications

The 5000 system is most suited to situations where material or equipment that has a fire initiating potential is being moved. For example, the system can detect and prevent a FIRE from being imported into a protected area, as in the case of a burning road or rail vehicle entering a tunnel or building.

In addition the system can monitor for materials in transit, that have not yet reached a flame condition, but have sufficient energy to initiate a fire upon arrival at their destination.

A typical example is in the coal feed systems on power stations where coal on the 'out field stack' may very well smoulder with little adverse effect for long periods of time. However, if imported to the power station it may have devastating effects on conveyor systems, holding hoppers, blending plants, etc.

- ◆ *Conveyors*
- ◆ *Escalators*
- ◆ *Drying Lines*
- ◆ *Rail Systems*
- ◆ *Food Processing*
- ◆ *Road Tunnels*
- ◆ *Production Lines*
- ◆ *Baggage Handling*
- ◆ *Warehouse Robots*

### The System

The type 5011 based system comprises three primary elements - the sensor unit the controller, and an air supply. The latter is required such as to maintain a positive air pressure in the sensor enclosure, and to prevent dust settling on the detector window. This air purging is essential in dusty environments such as coal conveyors, and is recommended in even relatively clean applications. A 0.25 inch NPT fitting is provided for connection to a 10 PSI compressed air supply.

The 5011 sensor unit is located above or beside the materials transit path (conveyor, roadway, etc.) by means of the adjustable mounting bracket and aligned such that the monitored hazard passes through the sensor's field of view. The distance and angle of the sensor determine the width of the monitored path.

Typically conveyor widths of 1.6 to 4.2 m can be monitored with a sensor mounted 1.0 to 1.5 m above the conveyor at an angle of 0° to 55°.

The air supply is monitored by a pressure switch which on air failure is signalled as a fault status. Alarm (Fire) conditions may be set for double knock operation.

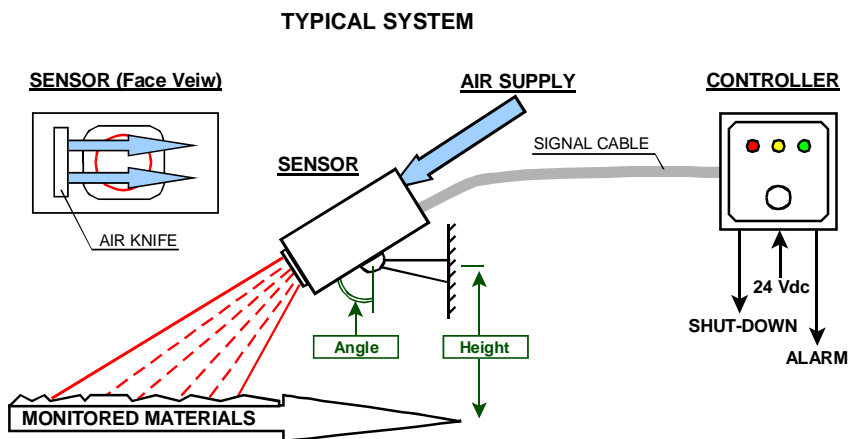

## TYPE 5011 / 5020 INFRA-RED FIRE & HEAT DETECTORS

### Sensor Unit

A quadruple channel detector sensing module is located within an aluminium alloy housing which is mounted by means of an adjustable bracket permitting alignment in both vertical and horizontal planes. The housing is equipped with an compressed air connector, signal cable conduit hub and internal screw terminals. In addition to the lens cleansing air knives a positive pressure is maintained in the enclosure which may be monitored by connecting a gauge to the fitting provided, and adjusted by means of bleed valves.

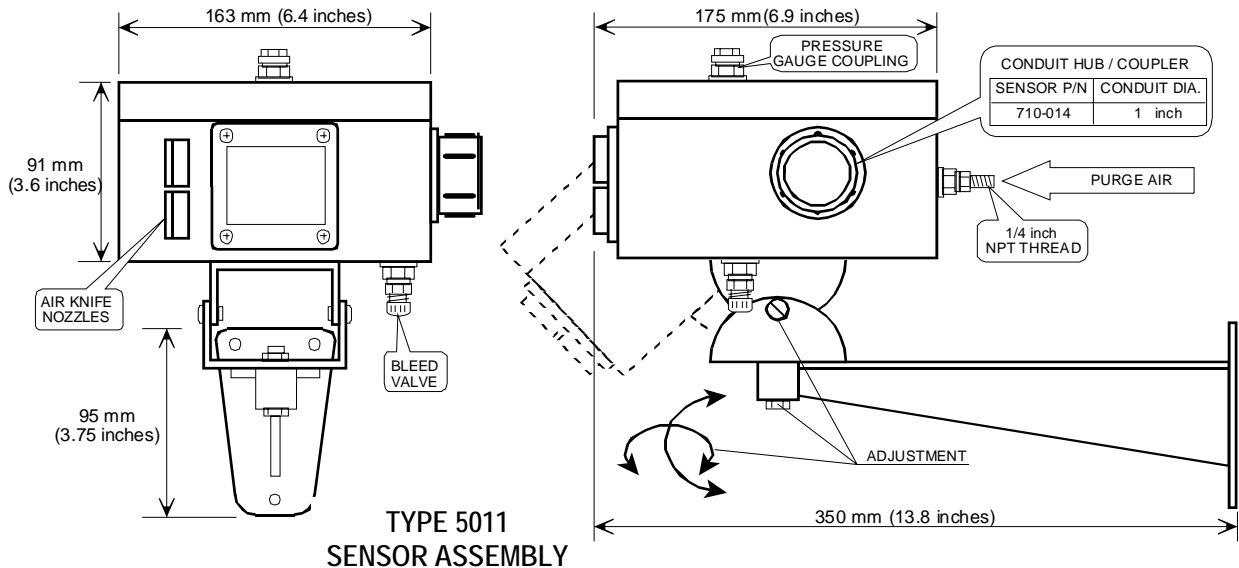

### Controller

The control module is easily de-mountable from the housing and connects to the sensor by means of a ten core cable. These terminations, together with supply and output contact connections are via two part screw terminals thus enabling installation of the housing and site cables prior to fittment of the module. Standard housings have a high level of ingress protection (IP67).

The module can be provided fitted into an outer control panel together with power supplies, battery chargers, DIN rail terminals, etc. as required.

The unit incorporates a user programmable DIL switch to set the options which include detector sensitivity setting, auto/manual reset sequence selection, and one-shot/coincidence voting for the alarm and trip/shutdown outputs.

The sensor air pressure and signal cable connections are fault monitored/fail safe. The unit incorporates an aux. fault input & common fault output contact.

- ◆ Quad Detectors
- ◆ Solar Blind
- ◆ Pressure Switch
- ◆ Sensitivity Control
- ◆ Voting Logic
- ◆ Latching Option
- ◆ Pre-Alarm Function
- ◆ Shut-down Output
- ◆ Fault Monitored
- ◆ Local Indicators
- ◆ Programmable
- ◆ Test & Reset PBs

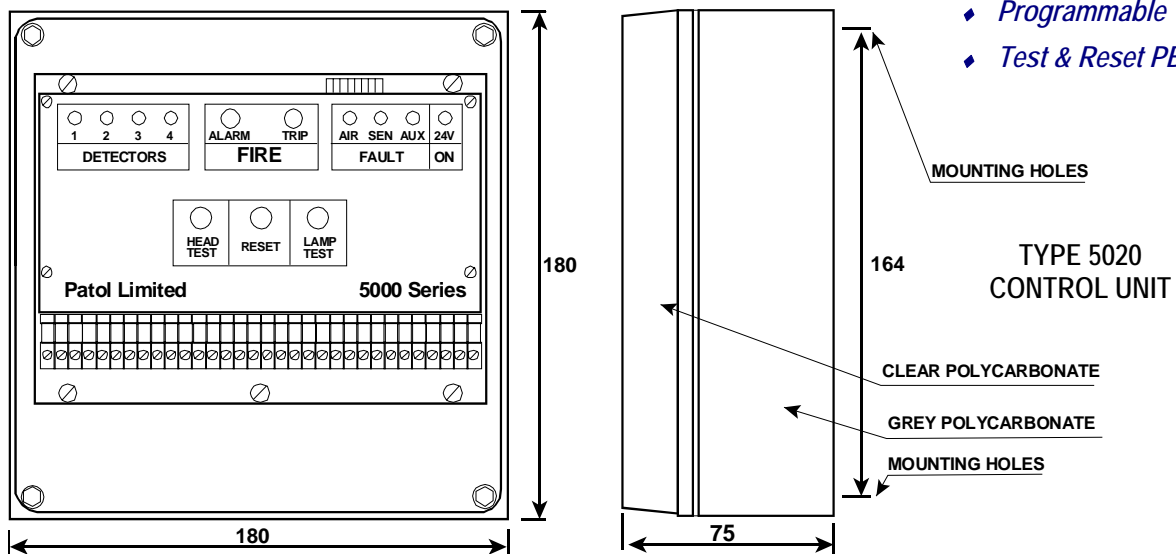

## TYPE 5011 / 5020 INFRA-RED FIRE & HEAT DETECTORS

### *Air Purging*

The sensor unit is equipped with a 1/4 inch NPT fitting for connection to a compressed air line which must be regulated at approximately 10 P.S.I. external to the casing. Should this be significantly exceeded then it must be noted that it could cause damage to the unit. There is an internal pressure switch monitoring the purge air presence.

### *General Specification - Sensor / Controller*

Supply Voltage:- 20 - 30 Vdc  
 Supply Current:- 35 mA Stand by  
 70 mA Max / Full Alarm  
 Temperature :- -20°C to +70°C  
 Indications:- Detectors - 4 off - Red LEDs  
 Alarm - Red LED  
 Trip (S/D) - Red LED  
 Fault - 3 off - Yellow LEDs  
 (Air / Sensor / Auxiliary)  
 Supply On - Green LED  
 Outputs:- Alarm Contact - 1 pole C/O  
 Trip Contact - 1 pole C/O  
 Fault Contact - 1 pole C/O  
 Rating - 30 Vdc - 500 mA  
 Controls:- Sensor Head Test PB  
 Reset PB  
 Lamp Test PB  
 Program DIL switch.  
 Auxiliary input:- PSU / Charger etc.  
 DIL Switch :- Sensitivity - 4 level  
 Latching / Auto Reset  
 Alarm - One Shot / Voting  
 Trip - One Shot / Voting  
 Auto Reset Timer - 4 settings  
 Purge Air :- Input Fitting : 1/4 inch NPT  
 Pressure : 0.7 Bar (10 PSI)  
 Delivery : 1.9 litres / sec  
 (4 cubic feet per min)

Sensor Head:- Weight : 2.3 kg (5 lbs)  
 Rating : IP67 (NEMA 4)  
 Controller:- Weight : 0.9 kg (2 lbs)  
 Rating : IP67 (NEMA 4)

Sensor Mounting:-

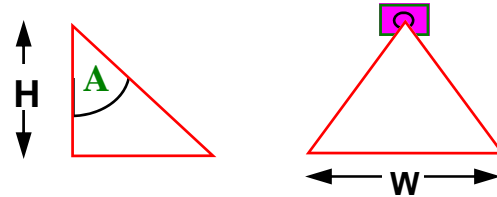

Height <b>H</b>	Angle <b>A</b>	Monitored Width <b>W</b>
1.0 m	30	1.6 m
1.0 m	45	2.0 m
1.1 m	45	2.2 m
1.2 m	45	2.4 m
1.3 m	45	2.6 m
1.4 m	45	2.8 m
1.5 m	45	3.0 m
1.5 m	55	3.6 m

Detectors:- 8 off - Interlaced lensing  
 Configured as 4 pairs.  
 Spectral Filter:- 5 - 14 μm  
 Transit speed:- 2 to 6 m/s (Std. Cal.)  
 Energy Response:- 80 - 1000 °C (Target  $\Delta$ ) \*  
 (Emission Spectra) (170 - 1800 °F)  
 Example :- 200 mm dia. at 180 °C \*  
 (Level 3 sensitivity) (50 sq inch at 350 °F)

**\* Also See Chart Below**

The chart (right) indicates the correlation between the temperature and size of 'hot spot' anomalies for a typical installation to produce one or more detector channel activations at various trigger level settings.

Exact response is dependant on the emissivity factor of the monitored material, sensor orientation and target speed.

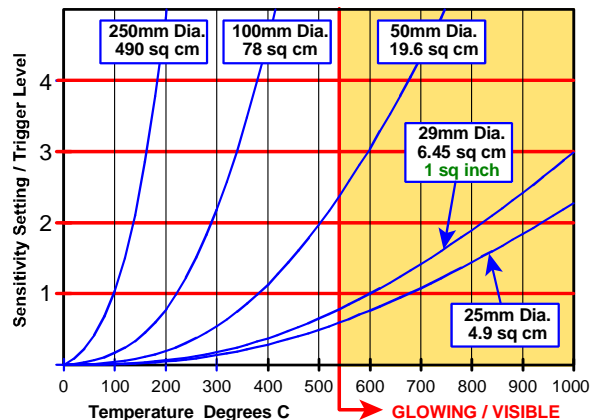

## TYPE 5011 / 5020 INFRA-RED FIRE & HEAT DETECTORS

### Connections

A multi-core screened cable is normally required for connections between the controller and sensor head. The remainder of the terminals located in the controller provide various supply, output, and signal functions.

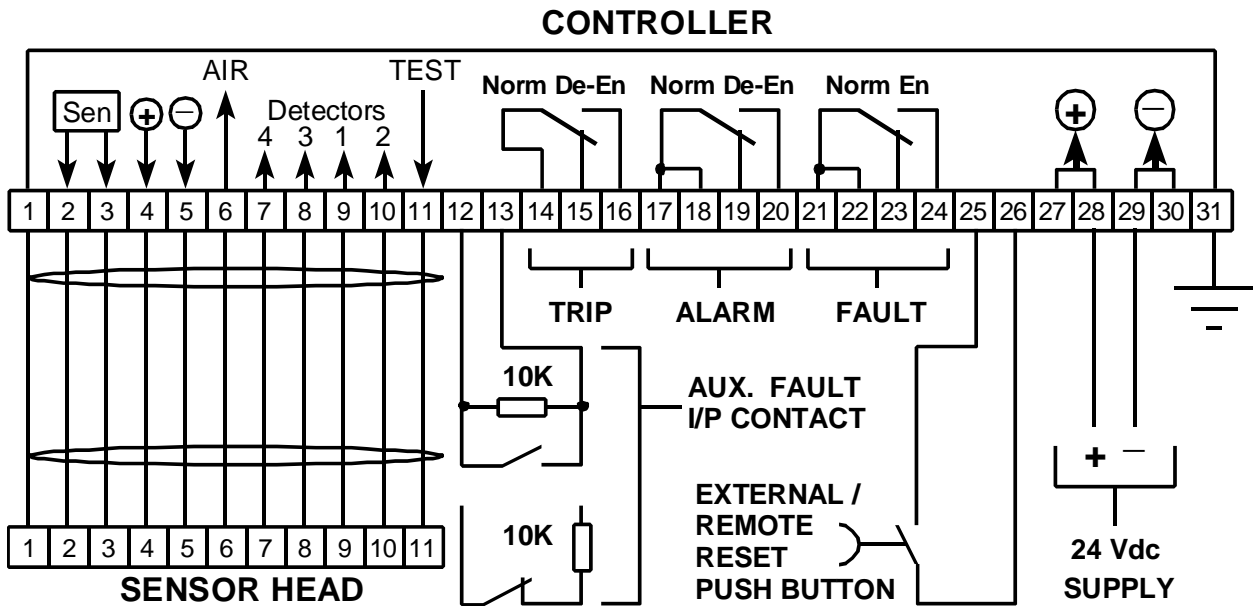

### Sensor Head Cable

A flexible screened ten core cable is required for connection at the sensor head. Patol can provide suitable cables. If it is necessary to install an extended interface cable between sensor head and controller it is suggested that a junction box is installed in proximity to the sensor head and any wire armoured or fire proof cables are terminated at this. A flexible "screened" cable being employed between JB & sensor head. Earth continuity at controller & sensor head terminals (No.1) should be maintained as is most appropriate.

### Auxiliary Fault Signal

The controller incorporates an auxiliary FAULT input circuit. This may be employed, for example, to integrate a fault signal from an associated local 24 Vdc power supply / battery charger. The circuit connection is both open & short circuit fault monitored. The above diagram shows how both opening and closing reporting contacts should be configured. If the circuit is not utilised then the terminals should have a 10k resistor connected to *blank off* the indication / warning.

### Reset Signal

The controller incorporates a remote / external RESET input circuit. This may be employed for integration with an overall shutdown system. The control unit has an integral reset push-button, however, the action of removing the controller cover in order to activate this device may be deemed to be inappropriate to normal site operation. An external reset control can be either remotely located, or mounted on the controller case.

### Relay Contacts

The controller provides three sets of repeat signal contacts. The above diagram shows the contacts in their *DE-ENERGISED* condition. Alarm & Trip contacts are normally de-energised; the fault contact is normally energised. The operation of Alarm & Trip contacts may be programmed by means of the DIL switch (see page 6/7).

### Supply, Earth, & Repeat Signals

Both the supply terminals and Alarm/Fault relay common contact terminals are duplexed in order to facilitate cable schemes that integrate two or more controllers and/or employ repeat signal schemes that require the fitting of EOL / Alarm resistors. It should be noted that the recommended EARTH connections are related to RFI considerations and must not be taken as being compliant with any site SAFETY EARTH requirements.

**TYPE 5011 / 5020 INFRA-RED FIRE & HEAT DETECTORS*****Operational Programmability***

The DIL switch located at the top of the controller PCB permits the selection of system parameters. These being - Sensitivity - Scan Period - Alarm/Trip mode -

Auto-Reset/Voting regime. A description of the unit operation and the programmable functions that the switch may define is as follows:-

- A) The system is fitted with eight IR detectors that are arranged in pairs within a four channel configuration. The controller DIL switch permits detector activation selection from four trigger levels. (this is in effect a sensitivity adjustment)
- B) The controller is equipped with two logic functions. The output of one function occurs when **any** channel registers a detection (1 out of 4). The other function operates on a voting principle, the output of which is activated when two **coincident** channel detections occur (2 out of 4).
- C) The controller is designed such that two IR indications and output signals are available. ALARM & TRIP (each of these having both a discrete LED indicator & output relay contact) The DIL switch permits selection of these as follows:-
- ALARM on **any** (1 out of 4) detection - TRIP on **any** (1 out of 4) detection.
  - ALARM on **any** (1 out of 4) detection - TRIP on **coincident** (2 out of 4) detection.
  - ALARM on **coincident** (2 out of 4) detection - TRIP on **coincident** (2 out of 4) detection.
- D) The **COINCIDENCE** of two detections has to be considered within the following :-
- The period or **scan** within which the coincidence has occurred
  - The speed of the belt related to the "detection foot-print"
  - The hazard in respect of its "profile"

The **scan** or **reset delay time** may be set by means of the DIL switch.

The time aspects of the above are related primarily to auto-resetting features (see following)

- E) The DIL switch permits all detections to LATCH ON - Similarly the system may be set such that all detections will AUTO-RESET
- One of the DIL switch selections permits single detections within the **scan** to auto-reset whereas **coincident** detections will latch on. (see over for DIL Switch settings)

***Controller Push-Buttons***

The function of Reset & Lamp Test push-buttons is as described by their titles. The Reset PB permits manual resetting of latched Alarm / Trip conditions. The Lamp Test PB illuminates the controller's LED indicators - output relays are not initiated. In the case of Head Test, operation of the PB signals the sensor head and simulates a *detection* condition on all circuits. The system will respond as if a true Alarm / Trip condition has occurred, including operation of Alarm & Trip relay contact outputs. Whilst this facility does not actually test the lensing system and the IR response of the detectors all other electronics circuits from the "front end" interface onwards are exercised.

***Special Options and Configurations***

The controller can be provided with an outer housing and configured to suit specific applications and project requirements. Some of these options are shown below. For further information contact Patol.

- **Dual controller panels to monitor twin conveyors.**
- **Integral power supply units operating from 110 or 230 Vac.**
- **Heavy duty trip relay contacts.**
- **Integral standby battery support.**

## TYPE 5011 / 5020 INFRA-RED FIRE & HEAT DETECTORS

### Dil Switch Settings

POLE 2	POLE 1	LED & RELAY OPERATION
OFF	OFF	ALARM & TRIP functions both operated on <b>any</b> sensor head detector activation. ( 1 out of 4)
OFF	ON	ALARM & TRIP functions both operated on <b>coincident</b> (voted) head detector activation. ( 2 out of 4)
ON	OFF	ALARM & TRIP functions both operated on <b>any</b> sensor head detector activation. ( 1 out of 4) <b>as per 0-0</b>
ON	ON	ALARM operated on <b>any</b> detector activation - TRIP operated on <b>coincident</b> (voted) activation

POLE 4	POLE 3	LATCHING OPERATION
OFF	OFF	ALARM & TRIP functions both auto-reset (see scan / reset delay following)
OFF	ON	<b>1 out of 4</b> functions auto-reset after scan - <b>2 out of 4</b> functions latch if within scan period
ON	OFF	All detections will Latch On
ON	ON	All detections will Latch On

POLE 6	POLE 5	SCAN - AUTO RESET TIME DELAY
OFF	OFF	Scan / Delay 0.5s (Shortest)
ON	OFF	Scan / Delay 1s
OFF	ON	Scan / Delay 1.5s
ON	ON	Scan / Delay 2s (Longest)

POLE 8	POLE 7	DETECTOR SENSITIVITY
OFF	OFF	Level A (Most Sensitive)
OFF	ON	Level B
ON	OFF	Level C
ON	ON	Level D (Least Sensitive)

### Notes

It must be understood that the 5000 series equipment is designed to detect Infra Red emissions at levels that will provide alarm warnings for relatively low temperature abnormalities. Unlike Spark & Ember detectors, which are designed to detect **only** small high temperature / energy targets, the 5000 series unit employs the laws of physics such that the **consequential** results of such hazards may be identified. For example, the 5000 unit will respond to **both** a directly sighted small burning coal, **and / or** a circumstance where the *burning coal* is buried in a larger mass of non-ignited coal.

The device is not responsive to visible light frequencies. However, if a test was conducted that moved a 200W light bulb into the unit's field of view a trigger is likely to occur. This is not due to the visible light, but due to the temperature of the lamp's glass bulb, which may be in excess of 100 degrees C. The 5000 Sensor is responding to a "hot spot" as per its designed criteria.

Similarly the unit is "Solar Blind" in respect of incident light reflected from the sun or local luminaires. However, If directed directly at the Sun, the device will correctly respond - the Sun being a 6000°C high energy source.

In practical terms the detector should be directed at the conveyor / risk, not the sun.

Infra-red Web: [www.patol.net](http://www.patol.net)

Patol Main Web: [www.patol.co.uk](http://www.patol.co.uk)



## Patol Limited

Rectory Road, Padworth Common,  
Berkshire, United Kingdom. RG7 4JD  
Tel: +44 (0) 118 9701701 email : [info@patol.co.uk](mailto:info@patol.co.uk)  
Fax: +44 (0) 118 9701700 Web: [www.patol.co.uk](http://www.patol.co.uk)