

Aspirating Smoke Detection

ASD 531



The ASD 531 (Aspirating Smoke Detector) is the new generation of a highly sensitive, active smoke detection system. It is based on the successful ASD 535 and is particularly well suited for monitoring smaller areas and sampling distances where a reduced sampling pipe network is sufficient.

The ASD 531 consists of a fan, a highly sensitive smoke sensor, an airflow measurement system, and evaluation electronics. The fan draws in air through sampling holes from the room or facility being monitored and then through a sampling pipe to the evaluating processor unit. Here the air samples are continually monitored for smoke particles by the smoke sensor. Airflow monitoring ensures that the sampling pipe is constantly checked for pipe breakage and any obstruction of the sampling holes. The display and control panel of the evaluating processor unit indicates alarm, fault and status reports. Any increase in the smoke concentration levels are detected very early. Three fixed pre-alarms and one main alarm which can be forwarded to a fire alarm control panel via volt free relays contacts.

The ASD 531 is used whenever conventional point-type smoke detectors cannot be used. This may be due for example to ambient conditions (too hot, too cold, too dirty) or because operating conditions are such that access is highly restricted (Elevator Shafts, prisons, false ceilings, clean rooms, laboratories, etc.).

Features

Latest generation of aspirating smoke detectors for simple applications

1 sampling pipe / 1 detector

EN 54-20 classes A, B, and C

4 alarm levels (1 fire alarm, 3 fixed pre-alarms 30 / 50 / 70% when using RIM36 Module)

Response sensitivity settable from 0.006–10%/m

Insensitive to dirt particles due to particle suppression

Low noise level, compliant with ISO 11690-1

Perfected smoke detection with HD sensor (high-dynamic technology)

Low power consumption

Onboard Configuration

ASD PipeFlow calculation tool

Individually Replaceable Components (Sensors, PCB's etc)

Applications

Elevator shaft monitoring

Museums, galleries, theatres, and cinemas

Collections of cultural artefacts, historical buildings

Laboratory and research centres

Transformer rooms

Clean rooms

High and Low Voltage distribution cabinets

Display cases

CNC control systems

Prison cells

Protection of cultural assets

IT cabinets / small server rooms

Aspirating Smoke Detection

ASD 531

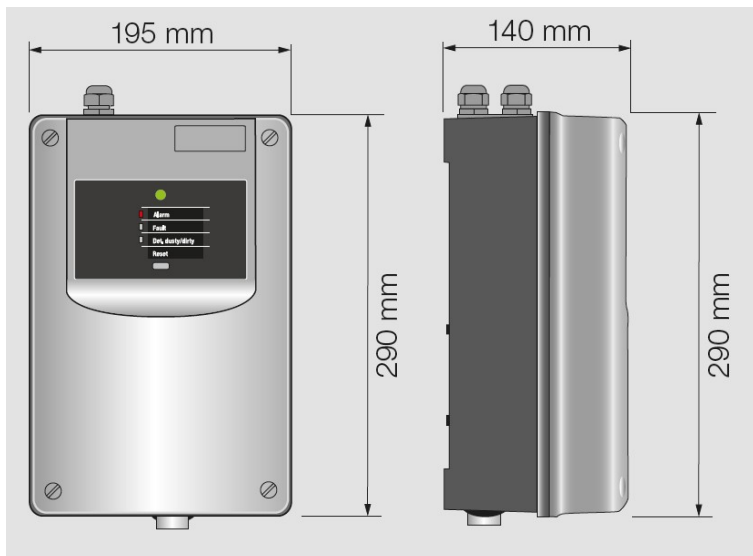

A high-power LED combined with a Large Volume Smoke Chamber (LVSC) results in unparalleled adjustable sensitivity (dynamic range of 0.006%/m to 10%/m) with low aerodynamic resistance and the utmost resistance to dust contamination. These features ensure long system service life and durability.

The ASD 531 is an Out Of The Box Operation unit with commissioning and maintenance made directly on the device using BasiConfig in just **three simple steps** using simple sample hole size look up tables, without the need for a PC.

ASD PipeFlow software can also be used to calculate the pipe distance and sample hole sizes while still maintaining EN54 part 20 approval. This makes it possible to configure more cost-efficient asymmetrical pipe layouts. The optional SD memory card allows extensive long-term smoke level recordings (e.g. smoke and airflow values) to be stored directly on the SD memory card and analysed on your PC.

Accessories and options

The ASD 531 is compatible with all the usual sampling tubes with D=25mm and other accessories. All of these can also be calculated using ASD PipeFlow.

The device concept is compatible with the use of the following options:

- Relay interface module RIM36

Specification

Supply Voltage:	14 - 30 Vdc
Supply Current:	75mA Quiescent (typical) (@ 24 Vdc)
Alarms 1:	0.02 - 10%/m (0.00087-0.457 dB/m)
Pre-alarms 1, 2 & 3:	0.006 - 9%/m (Fixed 30 / 50 / 70%)
Interfaces:	
Alarm, Fault, Prog	3 Relays / Open Collector
No. of Expansion:	1 Slot (1 x RIM36)
Relay Rating:	30 Vdc / 1Amp
Standards:	EN 54-20, classes A, B and C
Approvals:	VdS G 215 100
Temperature:-	-10°C to +55°C
IP Rating:	IP 54 (achieved without limitations)
Enclosure:	
Dimensions:	290mm x 195mm x 140mm (h x w x d)
Colour:	RAL 280 70 05 and RAL 300 20 05
Material:	ABS blend, UL 94-V0
Weight:	Approx 1,950g
Event Memory:	Max 1000 events (Onboard)
Analogue Logging:	Max 1 year events (with SD Card)
Cable Entries:	3 x M20, 1 x M25
Fan Type:	Radial - (1 fan speed only)
Suction Noise:	25 dBA Typical
System Limits:	
EN54-20	Class A: 6 Sampling Holes Class B: 8 Sampling Holes Class C: 12 Sampling Holes 40m Last Sampling Points 75m Total Pipe Length per Unit

Ordering Information

Description	Part Number
Aspirating Smoke Detector ASD531	11-2000002-01-01P
Replacement Smoke Sensor SSD31	11-2200009-01-01P
Relay Interface Module RIM36	11-2200005-01-02P
SD Memory Card (Industrial Version)	11-4000007-01-01P
Sampling Pipe	Refer D1316