

Model 5410 Infra-red Transit Heat Sensor



**MANUAL
INSTALLATION - COMMISSIONING
OPERATION - MAINTENANCE**

Applicable to Unit Part Numbers 720-002 / 720-012
Serial Numbers 98538-01 onwards

Issue	Change	Date	Remarks
1	Original	18/03/09	Based on D1140
2	Table 3 - reference corrected to D	15/11/12	Page 8
3	New document format	18/12/14	
4	Font changed to standardise documentation	04/11/19	Non standard font

Contact Details:

Patol Limited
Archway House
Bath Road
Padworth, Reading
Berkshire
RG7 5HR
Tel: +44 (0)1189 701 701
Fax: +44 (0)1189 701 700
Email: info@patol.co.uk
Web: www.Patol.co.uk

INDEX

1. INTRODUCTION

- 1.1 General
- 1.2 Principles

2. EQUIPMENT DETAIL

- 2.1 General Description
- 2.2 Relay Mode
- 2.3 Low Power Mode
- 2.4 Sensor Arrangement
- 2.5 Specification
- 2.6 Operational Programmability - SIL Switch
- 2.7 Connections

3. INSTALLATION

- 3.1 Detection Coverage
- 3.2 Supply / Signal Cable
- 3.3 Purge Air Supply

4. COMMISSIONING

- 4.1 Cable Checks
- 4.2 Controller Set Up
- 4.3 Power Up Procedure
- 4.4 Purge Air Supply and Pressure Switch
- 4.5 Hot Body Simulation Tests

5. OPERATION

- 5.1 Normal
- 5.2 Alarm Condition
- 5.3 Reset
- 5.4 Fault Warning
- 5.5 Test

6. MAINTENANCE

- 6.1 General
- 6.2 Purge Air Filter
- 6.3 Fault Monitoring Functions
- 6.4 Infra-red Detection

1 INTRODUCTION

1.1 General

The Patol 5000 Series of equipment is specifically designed for the protection of establishments and systems where a movement of materials with a potential fire hazard is a routine occurrence.

The 5410 Sensor employs enhanced Infra-red monitoring technology that enables the detection of fire initiating materials, whilst they are being transported, and before they have reached a flame condition.

The system has many applications within industries such as Power Generation, Coal Mining, Process Plant, Road Transportation and Rail Networks and has been specifically designed to both meet the rigors of these environments and to provide the reliability required.

The equipment monitors for fire and fire potential of materials in transit. The system can detect anomalies where combustion has not yet been reached, but where there is sufficient energy for a fire initiation upon destination arrival.

A typical example is in the coal feed systems on power stations where coal on the 'out field stack' may very well smoulder with little adverse effect for long periods of time. However, if imported to the power station it may have devastating effects on conveyor systems, holding hoppers, blending plants etc.

- Detection of hazards at temperatures below flame point including both embers and buried hot spots.
- Air purged system for *Dusty* environments with air pressure monitoring.
- Two wire operation - Powered by direct connection to standard fire trigger circuits or addressable loop interfaces - Signalling mode user configurable to simulate smoke & heat detector protocols.
- Patol remote controllers/interfaces available for two wire operation.
- Volt free relay contact output operation selectable as standard.
- Twin high integrity detection circuit channels for maximum reliability.
- Unique reflective cone lensing system provides wide uniform coverage superior to some ember/spark detectors.
- Coincidence - *Double Knock* - option for unit detector channels as standard.
- Timed auto reset / coincidence analyser circuit.
- Tuned response - solar blind.
- High degree of ingress protection - IP66.
- Specifically designed for high EMC compliance - CE Marked.

1.2 Principles

The principle of operation is that temperature dependant black body emissions occur for all materials. These emissions range through the infra red spectrum to visible light. Both the wavelength and level of peak energy emission are related to temperature.

The 5410 Sensor are designed to detect the changes in these emissions that occur when a hot body enters the field of view of the detector.

By the use of both optical filtering and electronic analysis of the various parameters the system is blind to visible light from the sun or local luminaires, whilst being able to detect relatively low temperature material moving through the field of view.

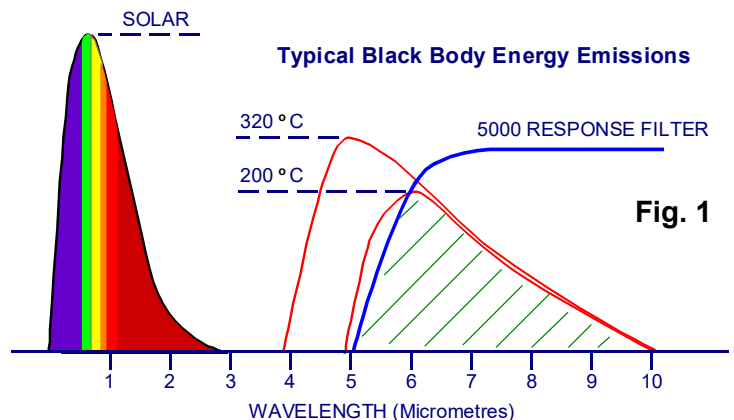

Fig. 1

EQUIPMENT DETAIL

2.1 General Description

The 5000 Series system described here comprises two primary elements :-

- Sensor Unit - Model 5410
- Air Supply / Blower Unit

The Sensor is located above the materials transit path (e.g. conveyor) by means of the adjustable mounting bracket and aligned such that the monitored hazard passes through the unit's field of view. The height and angle of the sensor determine the width of the monitored path.

The 5410 Sensor outer case is equipped with an air hose spigot for connection of an air supply. This is required such that a positive air pressure is maintained around the inner module sensor "windows".

There is a continuous air flow from the outer case optical path aperture which stops dust settling on the inner sensor module. Also, by maintaining a positive pressure within the enclosure, ingress of explosive gas or dust is prevented. The arrangement can permit the unit to be employed in a Hazardous Area depending on applicable local regulations.

The air purging is essential in dusty environments such as coal conveyors, and is recommended in even relatively clean applications. A series 5000 air purge blower and filter unit is employed when an 'on site' air supply is not available. (See section 2.7)

A pressure switch is located within the unit to monitor the purge air and signals a loss of pressure as a Fault

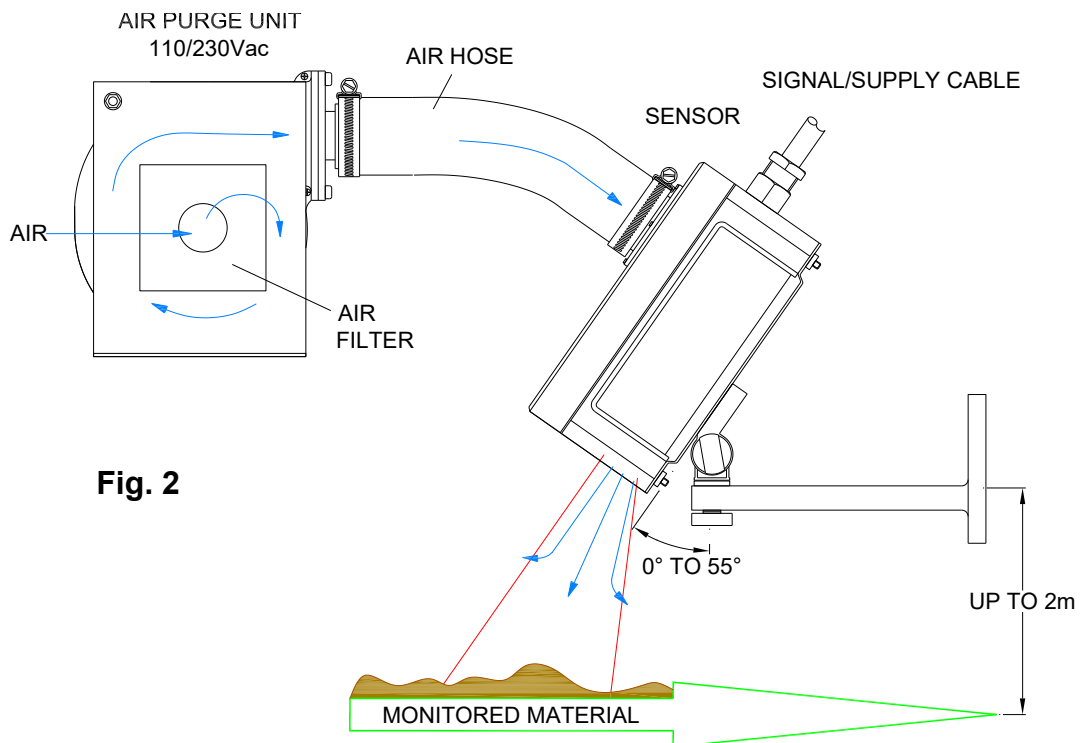

Fig. 2

The unit may be user selected to either of two principal operating settings which are referenced as :-

- "Relay Mode" - Operation from a 20 to 30 Vdc supply.
- "Low Power Mode" - Operation from a fire alarm trigger circuit / addressable loop.

A description of these arrangements is provided in sections 2.2 and 2.3 following.

2.2 Relay Mode

The unit is equipped with relays which are enabled in this mode.

A 24 Vdc (nom) supply is required to operate the unit (max current 24mA).

The unit's volt free relay contacts are used for signalling of Fire and Fault conditions.

The Fire relay is normally de-energised and energises on an infra-red detection alarm.

The Fault relay is normally energised and de-energises on power supply removal, module regulation failure or loss of purge air.

Refer to figure 3.

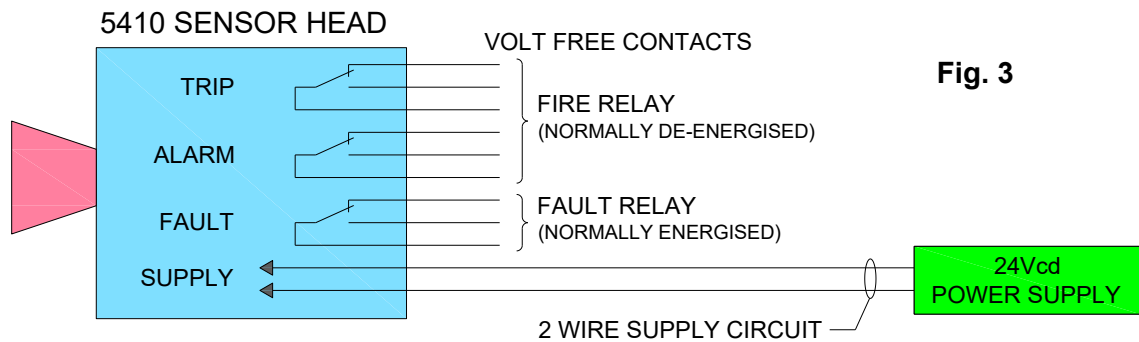

2.3 Low Power Mode

In this mode the relays are disabled and the unit's quiescent supply current is very low and of a similar level to conventional Smoke and Heat detectors.

By the connection of appropriate resistor values to the sensor's "solid state" outputs the unit will signal Normal, Fire & Fault conditions by line current levels, in a manner that permits the unit to be connected directly to fire control panels via alarm trigger circuits, or to the monitored inputs of addressable loop interface modules.

The unit can also be employed with the two wire connection to a remote Patol signal relay module.

Refer to figures 4 & 5.

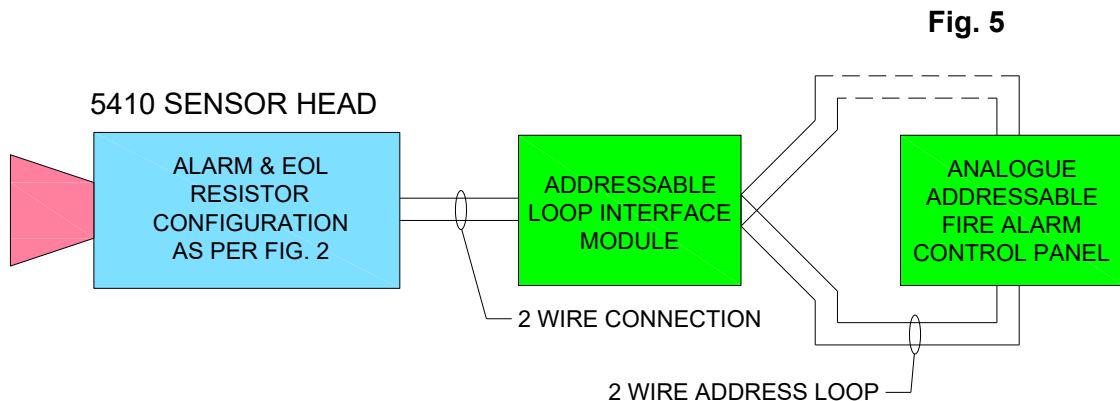
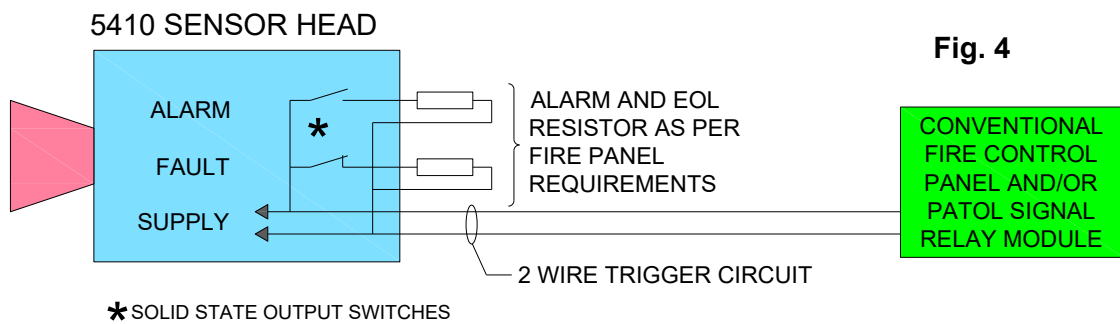

2.4 Sensor Arrangement

A dual detector channel sensing module is located within an ABS housing which is mounted by means of an adjustable bracket, permitting alignment in both vertical and horizontal planes. The outer housing is equipped with an air hose spigot. The signal cable enters through glands in both outer housing and inner module and is terminated at screw terminals. The inner module is rated IP66.

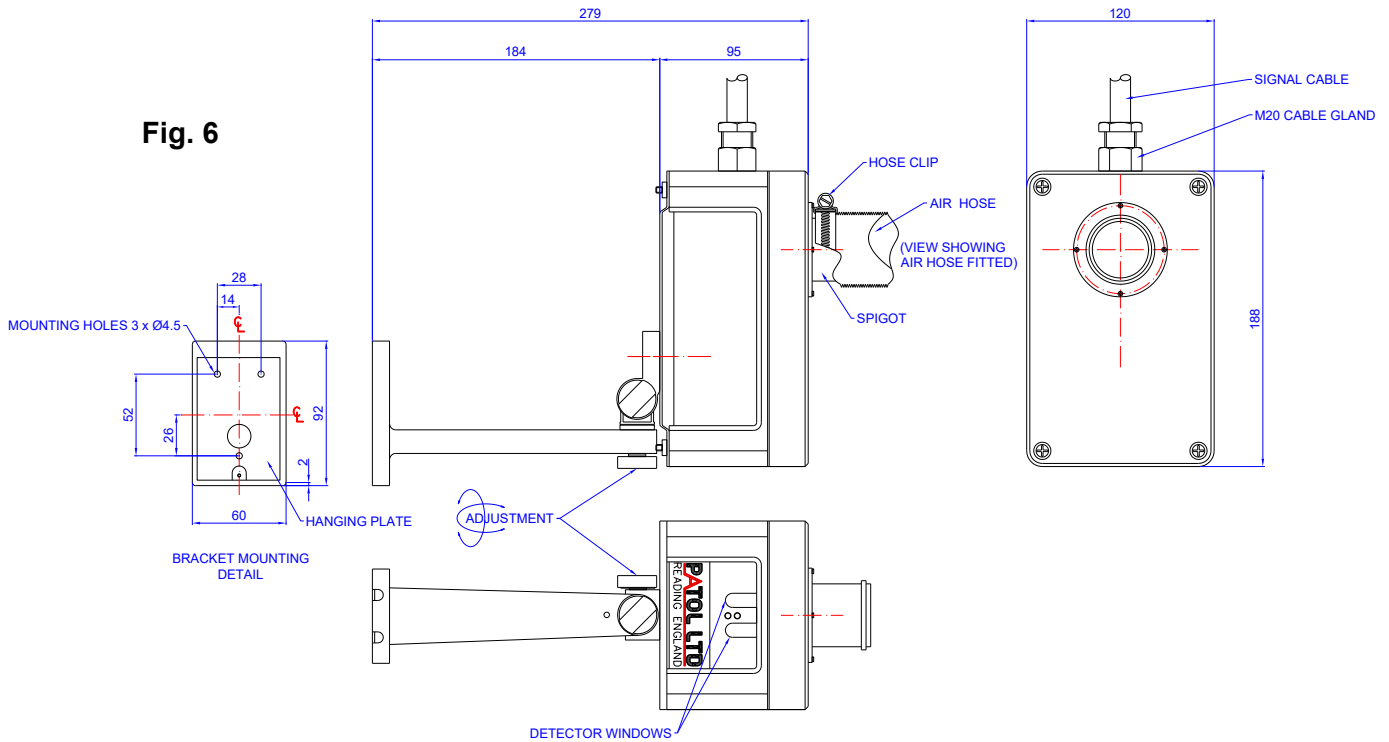

2.5 Specification

2.5.1 General

- | | | |
|-----------------------|---|--|
| a) Outer Case:- | Material: | ABS |
| | Finish: | RAL 7035 |
| b) Inner Module:- | Material: | Polycarbonate |
| | Finish: | RAL 7035 |
| | Ingress Rating: | IP66 |
| c) External Lamps | Green Normal LED
Red Trip LED | |
| d) Termination:- | Within inner module: Two part rising clamp terminals
Cable Core Size: 2.5mm ² - 14AWG | |
| e) Temperature :- | -20°C to +70°C | |
| f) Weight:- | 1.5 kg | |
| g) Purge Air Supply:- | Pressure: | 4 mBar (1.6" WG) |
| | Delivery: | 5.0 litres / sec (11 cubic feet per min) |
| | Input Fitting: | 45mm (1 3/4") dia. hose spigot |

Specification - Continued

- 2.5.2 Internal / Maintenance Features - Accessed on inner module cover removal
- a) Indications:- 2 off Red LEDs - One per sensor channel
 - b) Controls:- Test Push-button
Reset Push-button
 - c) Program Switch:- Sensitivity: 4 Levels
(SIL 8 Way) Alarm Operation: 'OR' / 'AND' - Latching / Auto-Reset
Auto Reset Timer: 4 Settings
- 2.5.3 Relay Mode - Direct Supply - Relays Enabled
- a) Supply Voltage:- 20 to 30 Vdc
 - b) Supply Current:- Standby - 11 MA Fire (Alarm) - 26 mA (max)
 - c) Alarm-Trip O/P:- Fire Relay Contacts - 2 sets
Volt free change over - 30 Vdc 500 mA
Normally De-energised
 - c) Monitor Output:- Fault Relay Contact - 1 set
Volt free change over - 30 Vdc 500 mA
Normally Energised - De-energises on supply / air failure
- 2.5.4 Low Power Mode - Line current signalling via Fire Alarm Trigger Circuit
- a) Supply Voltage:- 13 to 30 Vdc
 - b) Supply Current:- Normal / Standby - 1.8 mA (plus EOL *resistor current)
Fire (Alarm) - 5 mA (plus Alarm Load** resistor current)
Fault - <350 uA
 - c) Fire Output:- Solid state switch - Fit with Alarm Load** resistor
Normally Off - Alarm Load switched across supply on fire
 - c) Fault Output:- Solid state switch - Fit with trigger circuit EOL* resistor
Normally On - EOL open on Fault (supply <11V / air failure)
- 2.5.5 Detectors
- a) Configuration:- 2 off - Employing reflective cone optical focusing system
Coincident fields of view arranged as separate channels
 - b) Field Of View:- +5°/-15°(along transit axis path) +/-38°(across transit path)
Refer to coverage chart in section
 - c) Characteristic Spectral Filter: 5 - 14 μm
Sensitivity: 10 - 40 μW
Transit speed: 0.5 to 6 m/s
Response: 80 - 1000 °C (170 - 1800 °F) - See below

Figure 7; Indicates the correlation between the temperature and size of 'hot spot' anomalies for a typical installation to produce one or more detector channel activations at various trigger level settings.

Exact response is dependant on the emissivity factor of the monitored material, sensor orientation and target speed.

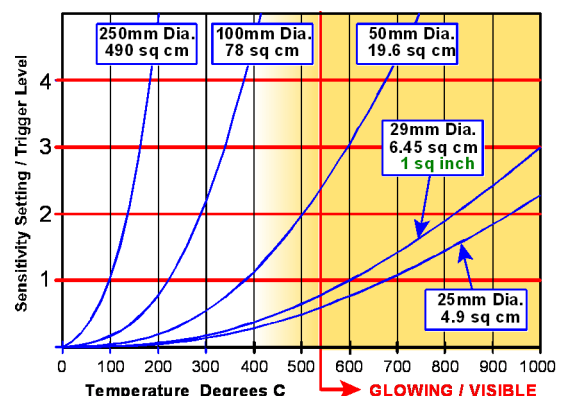

2.6 Operational Programmability - SIL Switch

An eight pole SIL switch is located within the inner sensor module which programs the unit’s operation. Most of the various option features are for special applications, factory test, commissioning or maintenance purpose.

A summary of the switch functions is as follows:-

2.6.1 LED Operation - Pole 1

Normally the internal LEDs will only illuminate on ‘Alarm’ signalling. In the case of coincident (double knock) operation the LEDs only illuminate when both channels have triggered. This is to obviate momentary increases in line current for single channel operations. For factory test and maintenance purpose Pole 1 of the switch allows the LEDs to individually illuminate irrespective of operating mode. Ref. table 1.

2.6.2 Channel AND / OR selection - Pole 2

The unit can operate such that detection by either sensor channel results on an alarm output (single knock / OR operation). Alternatively the unit may be set an alarm output only occurs on detection by both sensor channels (double knock / coincident / AND operation). Refer to table 1.

2.6.3 Non-latching option. - Pole 3

The sensor channels normally latch on detection. A non-latching setting is available for maintenance, factory test and special application analysis. Refer to table 1.

2.6.4 Auto Reset operation. - Pole 4

When in double knock mode an auto reset is applied after a preset delay .

This only occurs if only a single channel has operated within the delay time. If both channels have operated then the auto reset is prevented. The delay time is in effect the scan period for coincidence. An option to auto reset ‘AND alarms’ is provided for maintenance test purpose. Refer to 2.6.5 and table 1.

2.6.5 Auto Reset Delay (Scan Period) - Poles 5 & 6

The duration is set by these switch poles . Refer to table 2.

2.6.6 Sensitivity. - Poles 7 & 8

The unit detection level sensitivity is set by these switch poles. The range approximates to 10-40µW. Refer to table 3.

Table 1

Pole		FUNCTION
1	OFF	Internal Channel LED’s only illuminate on alarm
	ON	Internal Channel LED’s illuminate before D/K alarm
2	OFF	Double Knock - Coincident Output
	ON	Single Operation - OR - Output
3	OFF	Latching Operation
	ON	Non-latching Operation
4	OFF	Only single detections auto-reset after scan period
	ON	All detections auto-reset after scan period *

Table 2

Pole	AUTO RESET DELAY - SCAN PERIOD							
5	OFF	2.6s	OFF	1.3s	ON	0.9s	ON	0.6s
6	OFF		ON		OFF		ON	

Table 3

Pole	SENSITIVITY (A=Most : D=Least)							
7	OFF	A	OFF	B	ON	C	ON	D
8	OFF		ON		OFF		ON	

2.7 Connections

2.7.1 Relay Mode - Direct Supply - Relays Enabled

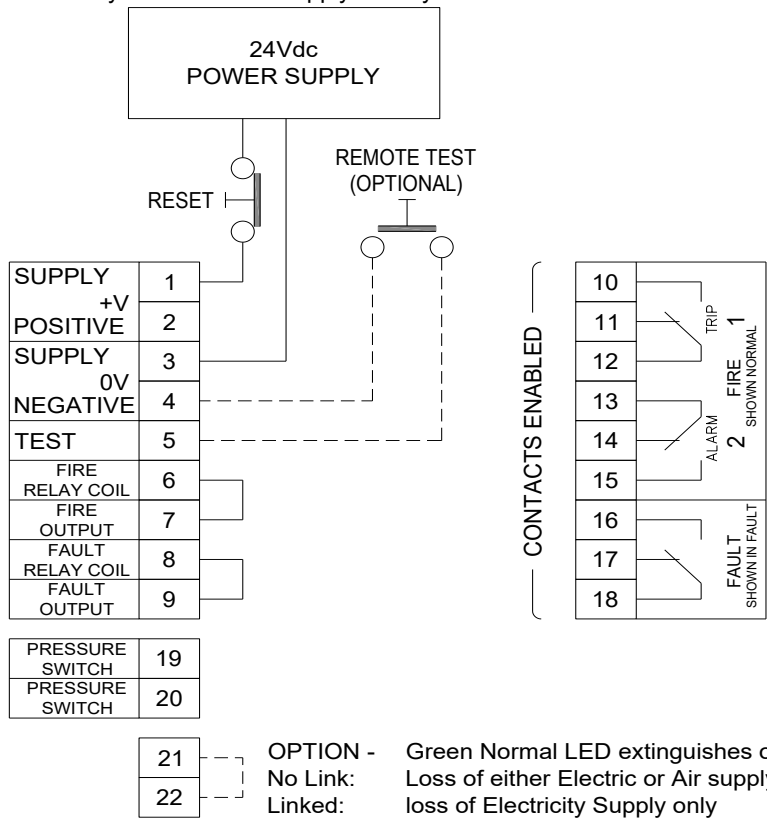

Fig. 8

Note : Pressure switch connected at terminals 19 & 20 - see Fig.13 Page 11.

2.7.2 Low Power Mode - Line Powered - Trigger Circuit Connection

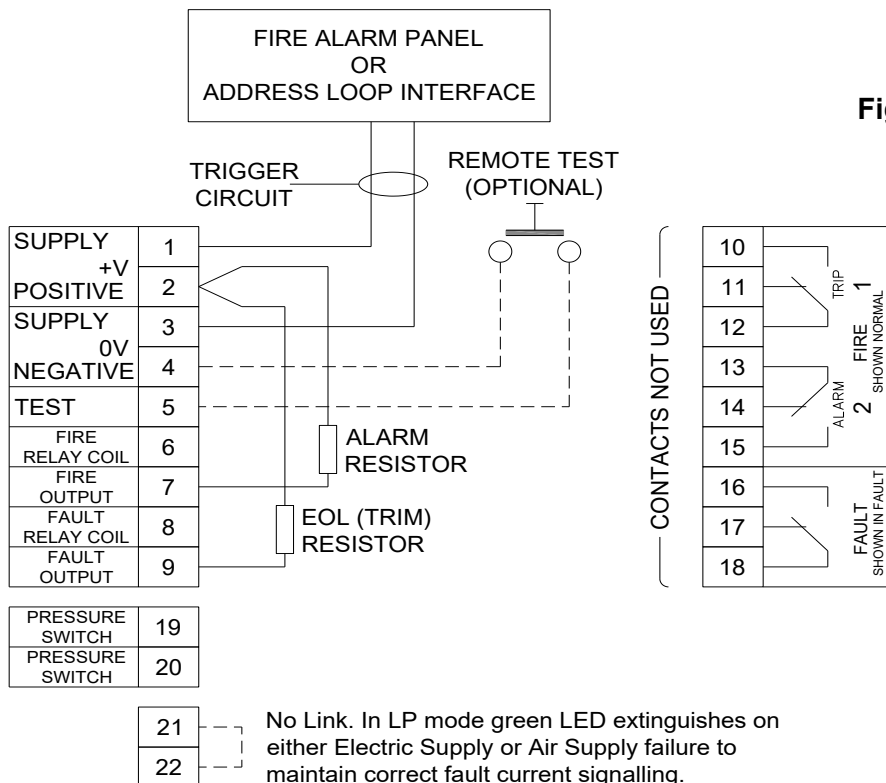

Fig. 9

Note : Pressure switch connected at terminals 19 & 20 - see Fig.13 Page 11.

INSTALLATION

3.1 Detection Coverage

The angle and height of mounting determine the monitored width.

Fig. 10

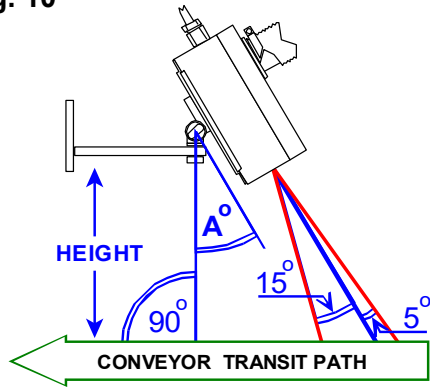

Fig. 11

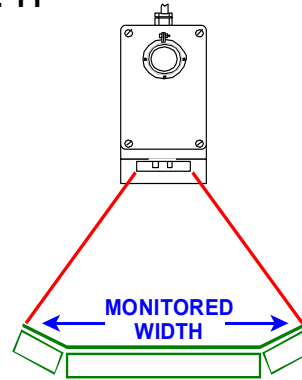
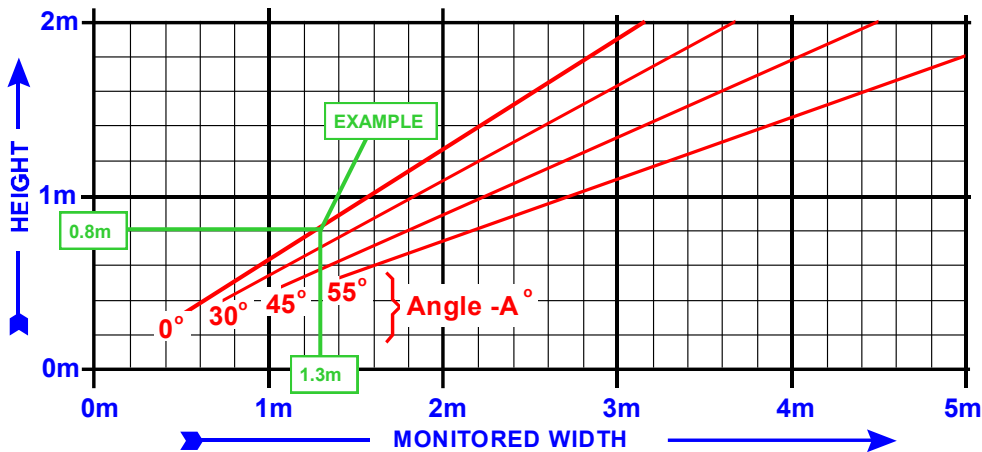

Fig. 12



The example shown on the chart is for a sensor mounted 0.8m above the transit path at an angle of 0°. This provides a maximum monitored width of 1.3m which would be suitable for most coal conveyors. Should the most practical mounting height (e.g. 1m) produce a wider view field than the conveyor this is perfectly acceptable, so long as the “overlap” on each side is not so large that external hot targets, such as vehicles on an adjacent roadway, are within the units view.

3.2 Supply / Signal Cable

The 5410 Sensor outer case is fitted with a 20mm gland as standard, which is suitable for cables of 6 to 12mm overall diameter. A second 20mm gland is fitted to the inner sensor module.

Cable terminations are made at plug-in rising clamp screw terminal connectors located within the inner module. The terminals accept wires of up to 2.5mm² (14AWG). Refer to section 2.7 for connections.

To access the terminals it is necessary to remove the covers / lids to both the outer case and the inner sensor module.

The air pressure switch is located on the inside of the inner sensor module lid. The switch wiring may be ‘un-plugged’ from the rear board by means of the two part terminal, and the air tube ‘A’ may be removed from the rear of case nipple in order to fully remove the module lid.

When re-fitting the inner module lid, the switch wires must be plugged into the rear board (TM 19/20), and air switch tube 'A' must be re-fitted to the nipple located at the rear of the outer compartment. When re-fitting the outer case lid it is essential that the air switch tube 'B' is inserted into the neck of the air inlet spigot such that the tube end lies in the air input hose.

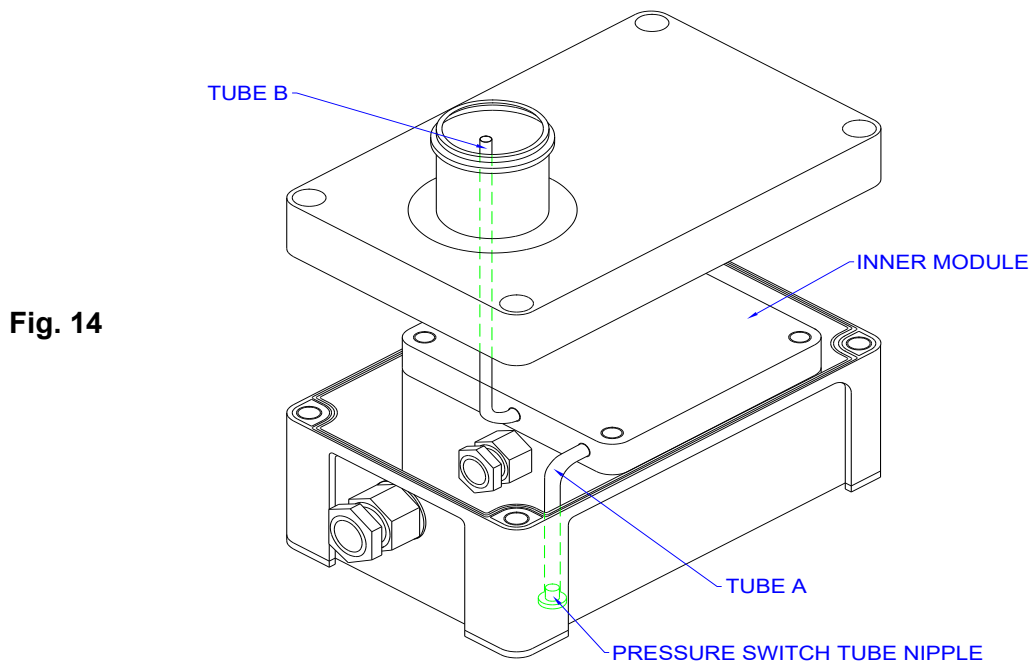
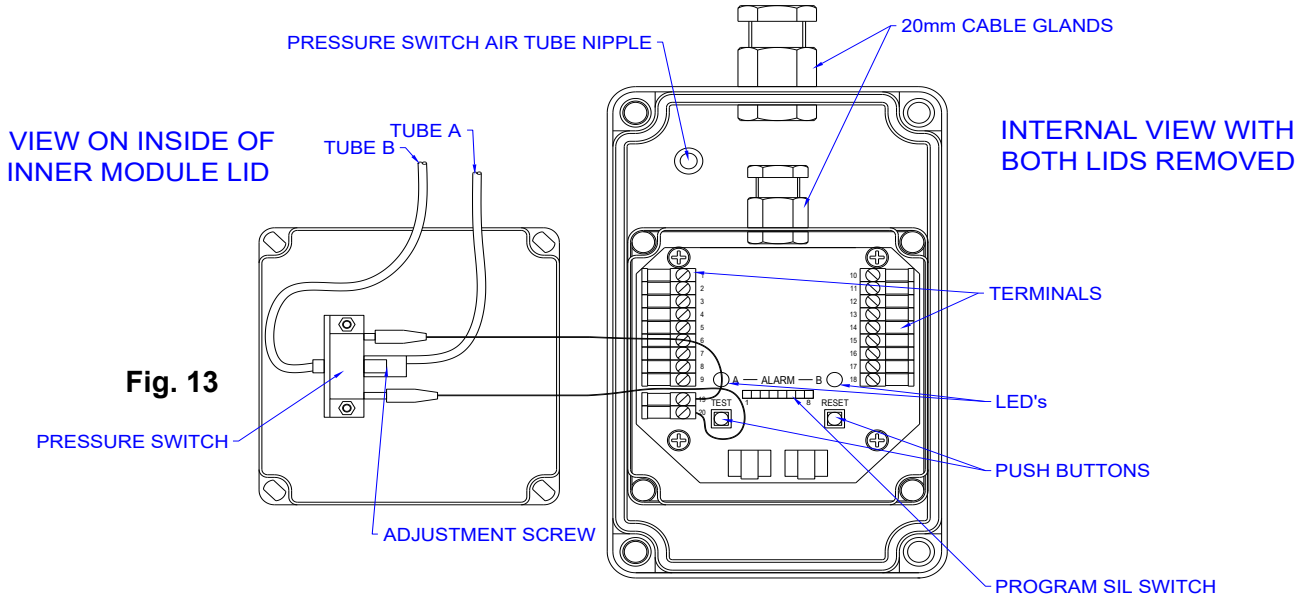

When armored cable or conduit is employed it may be most practical for these circuits to terminate at a junction box adjacent to the Sensor. A flexible cable should then connect the junction box to the Sensor in order to permit adjustments to sensing alignment.

On certain sites ("Hazardous Areas" for example) it may be a requirement that all cables are installed in conduit. In this case it is recommended that a short length of approved flexible conduit is fitted between the 5410 Sensor and an adjacent junction box. The outer case cable gland must be replaced with an appropriate flexible conduit coupler, which should be sealed with a suitable conduit sealant.

3.3 Purge Air Supply

The 5410 Sensor unit is equipped with a spigot for connection to a flexible hose. The air supply must be capable of delivering at least 5.0 ltrs/sec at this connection and maintain a minimum pressure of 4.0mBar (1.6" water gauge) in order to operate the sensor's pressure monitoring switch.

If an "on site" air supply is not available a Series 5000 Air Purge Blower (APB) should be employed. Some units are equipped with an easily removable and washable air filter, however these filters are intended to preserve blower life in *normal* conditions. The blower should either be installed outside the dirty/dusty area or the unit inlet piped to a *clean* air environment.

Intermediate rigid ducting is most readily achieved by the use of standard uPVC pipes and fittings. 2m of hose is provided with each purge unit for couplings at sensor & blower.

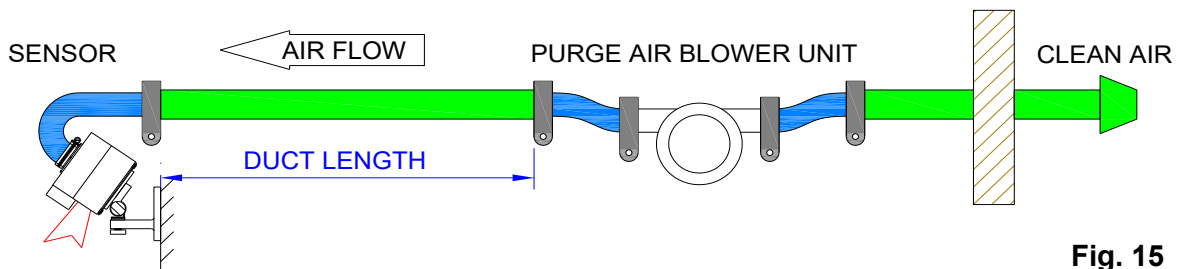

Fig. 15

In coal handling plant applications twin conveyors may be required to be monitored. A single blower may purge both sensors by employing a "T" branch in the air ducting.

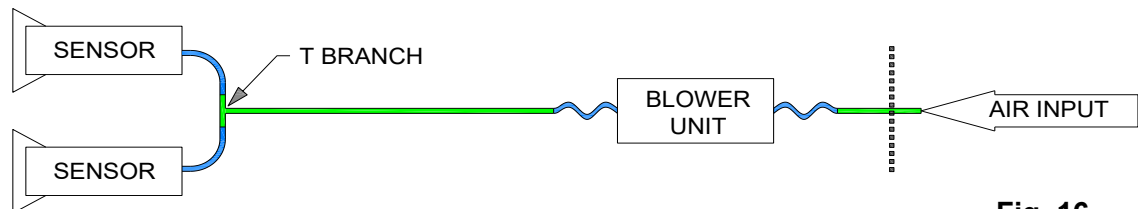

Fig. 16

In most applications the 'clean air' input will be quite close to the blower unit and sensor(s). In the case of over-ground conveyors, sufficiently clean air is simply obtained by ducting to the outside of the conveyor housing cladding. A minimal amount (<6m) of ducting being used.

However, in some applications (such as under-ground tunnels) the Sensor may need to be remote from a 'clean air' area.

There are limits to the distance that any APB can deliver the required air to the Sensor which are principally dependent on the APB specification and duct bore size. Other factors such as the ducting inner wall surface characteristic and the air temperature/pressure also have an effect.

For these 'long duct' applications consideration must be given to the exact installation ducting parameters, together with blower specifications.

COMMISSIONING

4.1 Cable Checks

The installation wiring should be checked for correct connection, continuity and insulation.

These checks should include cabling to both detector and air blower (if appropriate).

For relay mode implementation the relay coil link connections at terminals 6/7 & 8/9 should be checked. Refer to figure 8 section 2.7.1.

For line powered (trigger circuit) mode the Alarm resistor at terminals 2/7, and EOL (end of line) resistor at terminals 2/9 should be checked for both correct value and fitment. Refer to figure 8 section 2.7.1.

4.2 Controller Set Up

The Controller program SIL switch must be set for the required operation.

In most applications the selected operation will be for double channel coincident detection with the unit latching until manually reset.

It is recommended that initially, detection is set to the most sensitive level.

The SIL switch setting for this “Double Knock” configuration is:-

POLE 1	POLE 2	POLE 3	POLE 4	POLE 5	POLE 6	POLE 7	POLE 8
OFF	OFF	OFF	OFF	OFF	ON	OFF	OFF

4.3 Power Up Procedure

Note: The unit has three signaled / output states which are monitored by remote equipment. These are referenced as Normal - Fire - Fault in the following.

For relay mode: Normal = Fire relay de-energized & Fault relay energized.

For low power mode: Normal = EOL resistor connected across trigger circuit.

Fault = EOL resistor disconnected from trigger circuit.

Fire = Alarm resistor connected across trigger circuit.

4.3.1 Apply power to the detector. (Connect supply or trigger circuit)

Check supply = 20 to 30 Vdc for relay mode or 13 to 30 Vdc for relay mode.

Operate detector Test PB- Check: Internal & External Red LEDs illuminate.

Operate detector Reset PB- Check: LEDs extinguish.

4.3.2 A general check of detector field of view may be conducted at this stage whilst the module LEDs, Reset PB and SIL switch is still accessible. Refer to section 4.5.

For “Single Knock” mode Pole 3 may be set ON for non-latching alarms.

For “Double Knock” mode Pole 4 may be set ON for auto-reset.

The SIL switch must be returned to the setting of 4.2 before proceeding to 4.3.3.

4.3.3 Fit Sensor inner and outer lids, switch wires & air tubes . Refer to section 3.2.

Check that the air supply is connected and operational. If a 5000 Series blower is employed this must be powered.

4.3.4 Check at the Sensor that purge air is blowing from the optical aperture.

Check that the external Green LED is illuminated and the unit is signaling Normal.

Note: The purge air is monitored by a pressure switch located within the inner sensor module. If the air delivery is too low to operate the switch then the Sensor will signal Fault. The Green LED will extinguish (if appropriate). Refer to 4.4

4.3.5 Momentarily remove the purge air supply and check that the Green Normal LED extinguishes (if appropriate), and the unit signals Fault for the duration of the air supply interruption.

4.3.6 Momentarily remove the electrical supply and check that the Green Normal LED extinguishes and the unit signals Fault for the duration of the supply interruption.

4.4 Purge Air Supply, Pressure Switch and Normal LED

The purge air is monitored by a pressure switch located within the inner sensor module.

The operation of the switch is dependent on the differential pressure between the air input point to the Sensors outer case and the external atmosphere.

Terminals 21/22 permit selection of the Green Normal LED operation. When unlinked the LED extinguishes on either electrical or air supply failure. If linked the LED extinguishes on electrical supply failure only. This latter option is only permissible in Relay Mode.

Should the Sensor remain in Fault at stage 4.3.3, even though it is apparent that purge air is present, the switch's electrical connection and monitoring tubes should be checked for correct connection / positioning.

The switch is correctly factory set to operate at approximately 3.74 mBar (1.5 inch WG).

However, should the switch setting have become incorrect for the air flow/pressure being achieved on the installation, an on site adjustment can be made as in the following.

Check & Adjustment Procedure

Refer to section 3.2 - figures 14 & 15

- 4.4.1 Remove the outer case lid slowly such as to be able to check that the end of pressure switch Tube A was resident in the air inlet spigot / hose. Check that Tube B is fitted to the nipple at the back of the compartment.
- 4.4.2 Remove the inner module lid - this may require loosening of the outer case cable gland. Check that both tubes are fitted to the pressure switch and that the switch wires connect to the rear board via plug-in terminals 19/20.
- 4.4.3 If all tube and electrical connections have been correct then the pressure switch may need adjustment:-
 - Un-plug terminals 19-20 and monitor with a multi-meter set to ohms. The reading should be open circuit.
 - Using a screwdriver turn the adjustment screw clockwise until the switch closes - meter indicates zero ohms.
 - Turn the adjustment anti-clockwise (counter-clockwise) until the switch opens. Continue for one quarter of a turn.
- 4.4.4 Plug terminal 19/20 into the rear board connector and re-fit the sensor lid.
- 4.4.5 Re-fit the outer case lid ensuring Tube A is connected to the rear of case nipple, and the Tube B sits in the inlet spigot / hose.

4.5 Hot Body Simulation Tests

A heat simulation test should be conducted.

The test is conducted by moving a "hot" (IR emitting) target into the view field of the Sensor Head and observing / checking the consequential Alarm operation.

It is preferable that the "test target" is of sufficient size and temperature that the simulation can be conducted at the plane of the monitored path (conveyor) such that the view field of the Sensor can be validated. However, a smaller and cooler "test target" may be employed so as to at least confirm basic operation of the Sensor. It will be necessary with a "target" of this nature to introduce it to the view field nearer to the Sensor than the "monitored plane".

When the 5410 Sensor is connected to fire panel via a conventional trigger circuit or addressable loop detector interface, latched 5410 detections are normalized by Alarm Reset operation at the fire panel. Similarly, when in relay mode, reset is conducted by momentary supply interruption by an external push-button or other means.

Field of view test confirmation (which requires a number of alarm triggers) may more easily be conducted when the unit's covers are removed and the internal LEDs, Reset PB and program SIL switch are still accessible. Refer to section 4.3.2.

If the location of the Sensor is classified as a "Hazardous Area" it will be necessary to make special arrangements for this testing as the electrical / hot nature of the test simulation may breach normal site regulations. It may even be that the test is precluded.

Refer to section 6.4 for information on "test targets".

5. OPERATION

5.1 Normal

- External Green Normal LED - On
- Relay Mode:- Fault relay energized. Fire relay de-energized.
- LP Mode:- End of line resistor connected across trigger circuit.

5.2 Alarm Condition

An Alarm condition will occur on abnormal Infra-red detection by the Sensor Head.

Normally this status will Latch On, however in special configurations the condition can be set to momentary operation - auto resetting after a selected delay.

During the ALARM :-

- External Red Fire Trip LED - On
- Either or both internal red LED indicators illuminated.
- Relay Mode:- Fire relay energized.
- LP Mode:- Alarm resistor switched across trigger circuit.

5.3 Reset

Latched Alarm conditions may be normalized by :-

- Momentary interruption of the supply - less than 7V.
When directly connected to a Fire Panel via a trigger circuit or addressable loop interface this condition will occur on fire panel reset operation.
A local or remote normally closed push-button may also be implemented.
- Operation of the internal Reset push-button.

5.4 Fault Warning

- External Green Normal LED - Off *
- Relay Mode:- Fault relay de-energized
- LP Mode:- End of line resistor disconnected from trigger circuit.

A fault warning may occur for any of the following:-

- Low / failed supply.
Supply less than 20V in Relay Mode.
Supply less than 13V in LP Mode. (Note:- An Alarm will remain latched below the fault threshold so long as the Reset voltage is not reached.)
- Unit internal power regulation circuit fault.
- Loss of Purge Air *

The output will automatically normalize on rectification of the fault.

5.5 Test

Operation of the sensor's internal Test push-button simulates an alarm as per 5.2.

A remote test push-button has identical result if implemented.

*Note:- Linking terminals 21 & 22 provides an option where Purge Air failure results in 'Fault' signalling but the Green LED will remain illuminated whilst electrical supply is maintained. The option can only be employed in Relay Mode.

6. MAINTENANCE

6.1 General

It is recommended that a System Log Book / File is raised at the Commissioning Stage and that the system configuration and initial settings recorded. These should include:-

- Operation configuration and Sensitivity - SIL switch set-up.
- Supply voltage.

Subsequently all system events should be recorded in the log.

These should include all maintenance activity, changes to settings, Fault warnings and Alarm occurrences. (including cause and actions taken).

An operational regime should be developed that includes both frequent inspection of the Sensor for undue accumulation of dust, and to confirm air (blower) operation. The regime may encompass use of the Test facility to check basic operation.

In addition, the system should be subjected to a **periodic service** as defined in the following.

6.2 Purge Air Filters (if fitted)

Some blower units have integral air filters, and some installations may employ ducting filters. If installed these should be removed and washed using a warm water soap solution.

The use of solvent cleaners is not recommended for Patol Series 5000 blowers.

6.3 Fault Monitoring Functions

Tests should be conducted to confirm the correct operation of the fault monitoring circuits :-

- 6.3.1 Purge Air Pressure - Check as per 4.3.5
- 6.3.2 Supply Failure - Check as per 4.3.6

6.4 Infra-red Detection

A heat simulation test should be conducted by moving a "hot" (IR emitting) target into the view field of the Sensor and checking the consequential Alarm operation.

It is preferable that the "test target" is of sufficient size and temperature to enable simulation at the plane of the monitored path (conveyor) in order to validate the view field of the Sensor . Smaller and/or cooler "test targets" may be used closer to the Sensor so as to at least confirm basic operation of the Sensor.

Fig.7 in Section 2.5 indicates the relationship between the surface area and temperature required for triggering at the various trip settings.

It may be necessary to make special arrangements for this testing as the electrical / hot nature of the test simulation may breach normal site regulations. It may even be that the test is precluded.

Potential "test targets" are :-

Type 5501 Infra-red Radiator - Test and Commissioning Platen - Patol product.

100W Lamp Bulb - (The Sensor responds to the glass temperature - not the visible light).

Domestic Flat Iron (smoothing iron).

Electrical or Catalytic soldering iron.

Note : Infra-red LED Torches are NOT suitable for testing 5000 Series equipment.