

APPLICATION NOTE - LINEAR HEAT DETECTION CABLE – D1120

The use of LHDC in Hazardous Areas by means of Intrinsically Safe Barriers

Both Analogue and Digital Linear Heat Detection Cable (LHDC) may be installed in a “Hazardous Area” by the use of an appropriately certified Intrinsically Safe Shunt Diode Barrier. The Barrier must be installed between the LHDC and the Zone monitor (Interface circuit). Both Barrier and Zone Monitor must be located in a designated “Safe Area”.

The Linear Heat Detection Cable and End of Line Terminator (EOL) can constitute “Simple Apparatus” in both of the Analogue and Digital installation configurations. The approval certificate for any particular barrier will require that certain conditions are met, and it is important that the maximum permitted parameters associated with field mounted equipment are observed. These parameters are dependant on both the Gas Group classification within the hazardous area and whether the barrier circuits (channels) are interconnected in the hazardous area. .

For Analogue LHDC, Patol recommends that 22V to 28V zener barrier units are employed in combination with the range of Patol analogue LHDC zone monitoring units.

These 22/28V types are also often the most appropriate when Digital LHDC is operated directly in conjunction with 24Vdc fire system trigger circuits.

Figures 1 and 2 show a typical Analogue LHDC connection scheme. The arrangement uses dual channel barriers which means that whilst the supply 0V must remain within 2V of earth there is no direct circuit connection to the IS earth at the barrier.

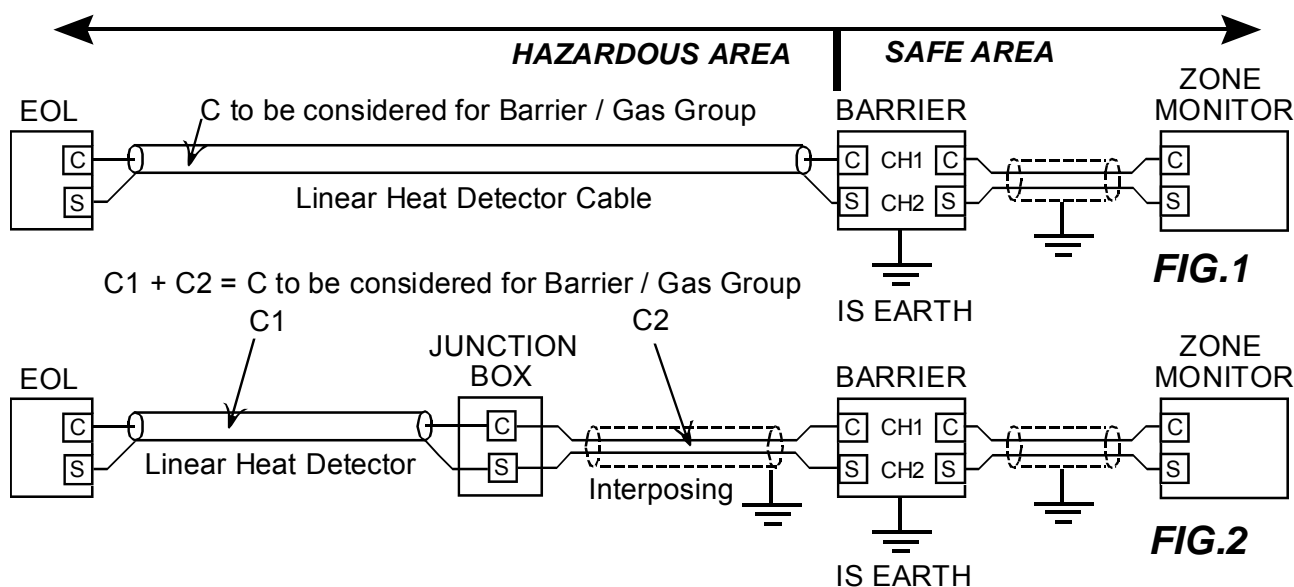

Patol Analogue EOLs comprise a 22M resistor and meet the “Simple Apparatus” criteria; their parameters being effectively inconsequential in relation to LHD cable characteristics.

Patol Digital LHDC monitor circuits employ resistive EOLs with similar “conforming” characteristics.

Digital monitoring circuits using “capacitive” EOLs are not recommended, and other techniques such as EOL zener diodes require special consideration .

Barrier examples which can be supplied by Patol are MTL778 & MTL7778 units which are both dual channel 28V 600 ohm A.C. shunt diode safety barriers. The maximum permitted hazardous area cable parameters for these particular units with the channels combined in the hazardous area are:-

MTL7778	EC Directive 94/9/EC (ATEX / BASEEFA)			FM
	Group IIA	Group IIB	Group IIC	
Combined Channels	Group IIA	Group IIB	Group IIC	Groups A & B
Capacitance	2.15 uF	0.65 uF	0.083 uF	0.083 uF
Inductance	33.6 mH	12.6 mH	4.2 mH	4.00 mH
L/R ratio	333 uH/ohm	158 uH/ohm	42 uH/ohm	107 uH/ohm

The characteristics of Patol LHDC are :-

	Capacitance	Inductance	L/R Ratio
Analogue LHDC - Standard	< 350 pF/m	< 0.5 uH/m	< 2.5 uH/Ω
Analogue LHDC - Braided Armour	< 540 pF/m	< 0.7 uH/m	< 20 uH/Ω
Digital LHDC - Standard	< 120 pF/m	< 0.95 uH/m	< 5.5 uH/Ω
Digital LHDC Braided Armour	< 230 pF/m	< 0.95 uH/m	< 5.5 uH/Ω

It can be seen from the above that in the case of a 28V MTL 7778 Barrier employed for Analogue LHDC, without any interposing cable, the limiting parameter for the **Group IIB** gas area is LHD cable capacitance, which is directly related to length.

In this example, the maximum permissible length would be:-

$$\frac{0.65\mu\text{F}}{350\text{pF}} = \frac{650000}{350} = 1857 \text{ metres}$$

From an Intrinsically Safe point of view 1857 metres may be acceptable, but with Analogue LHDC this zone length would most likely be further limited by the temperature length relationship for the installation. Ref. LHDC Data Sheet.

With higher voltage barriers the predominant factor is capacitance and as Digital LHDC has generally lower C/m, longer lengths may be installed than Analoue.

Example: Even with the most onerous parameter which is for gas **Group IIC** 691m of Standard Digital LHDC may be installed. $0.083\mu\text{F}/120\text{pF} = 83000/120 = 691\text{m}$

If it is necessary to "interpose" a cable between the LHDC and the Barrier, then the parameters of this cable must also be considered to ensure the Installation Conditions are met. It is also necessary for such cable to have a screen in the case of Analogue LHDC.

It is possible to employ other types / manufactures of barrier, however in addition to observing the intrinsically safe requirements of their certification, Patol does not recommend the use of barriers with less than 22V zener diode operation for Analogue LHDC.

The interfacing of Digital LHDC requires consideration of the specification of the interface / fire panel trigger (monitoring) input together with the various factors of the LHDC circuit.

A typical simplified schematic arrangement is shown in Figure 3.

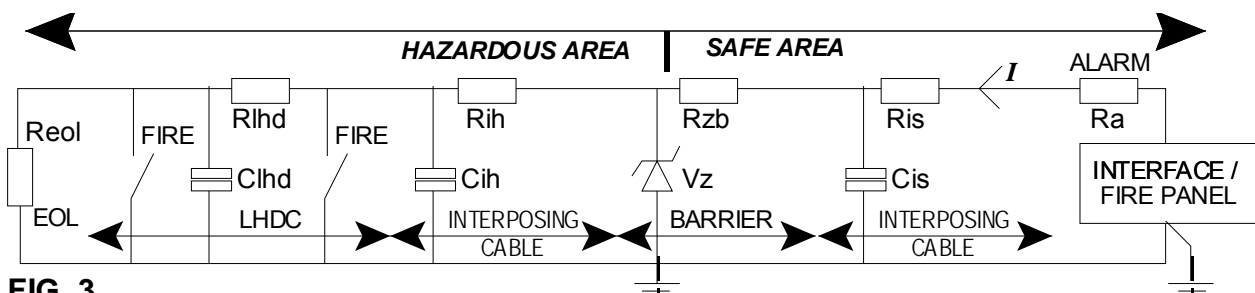

FIG. 3

Fire panel trigger circuits register a fire alarm when the trigger circuit current (*I*) increases beyond a set value. Most equipment has a further level which discriminates short circuit fault.

An Alarm resistor (*R_a*) may need to be employed, with a value such that when the LHDC operates at either end (Fire Sw. - Fig.3) the circuit current is within the equipment 'alarm window'.

EXAMPLE - LHDC is 184 Ω/km (loop) : Say 300m installed, $R_{Lhd} = 0.184 \times \text{length(m)} = 55\Omega$

For both channels of the MTL7778 Barrier $R_{zb} = 1302\Omega$

Say total hazardous area interposing cable resistance = 25R : non hazardous area = 10R

Fire resistance - Min : $R_{ih} + R_{zb} + R_{is} = 25 + 1302 + 10 = 1337\Omega$ - Max : $1337 + 55 = 1392\Omega$

It would probably not be required to fit *R_a* in this case – The fire panel must respond to 1k4.

Typically fire panel trigger circuits require an End Of Line resistor (EOL) in order to monitor the circuit for open circuit fault. It may be necessary to reduce the value of the actual resistor *R_{eol}* fitted to accommodate for the series resistance of the rest of the circuit ($R_{Lhd} + R_{ih} + R_{zb} + R_{is} + R_a$).

Circuit total = 1392 : If panel requires 4k7 EOL then $R_{eol} = 4K7 - 1392\Omega$: Fit 3k3 say.

Lower Voltage Zener Barriers

Lower voltage barriers may be employed for Digital LHDC, however in many cases it will be found that leakage currents through the Barrier zener will cause mal-operation of circuit monitoring with 24V fire system equipment.

It should be noted that with lower voltage zener barriers inductance usually becomes the predominant factor in determining LHDC zone lengths. There can be a length advantage with lower voltages, especially if single barrier channel configurations are employed.

Patol produces an interface module LDM-519-DDL which in addition to permitting the use of a 15V barrier provides a digital display of the distance to the 'fire'. See LDM-515-DDL Data Sheet D1137.

The recommended Barrier is MTL7765 which when employed in combined dual channel mode as per Figure 4 maintains earth isolation at the barrier.

The maximum permitted hazardous area cable parameters for the MTL7765 with the channels combined in the hazardous area are:-

MTL7765	EC Directive 94/9/EC (ATEX / BASEEFA)			FM
	Group IIA	Group IIB	Group IIC	
Combined Channels	Group IIA	Group IIB	Group IIC	Groups A & B
Capacitance	14 uF	3.55 uF	0.58 uF	0.58 uF
Inductance	2.54 mH	0.95 mH	0.32 mH	0.32 mH
L/R ratio	216 uH/ohm	108 uH/ohm	22 uH/ohm	32.6 uH/ohm

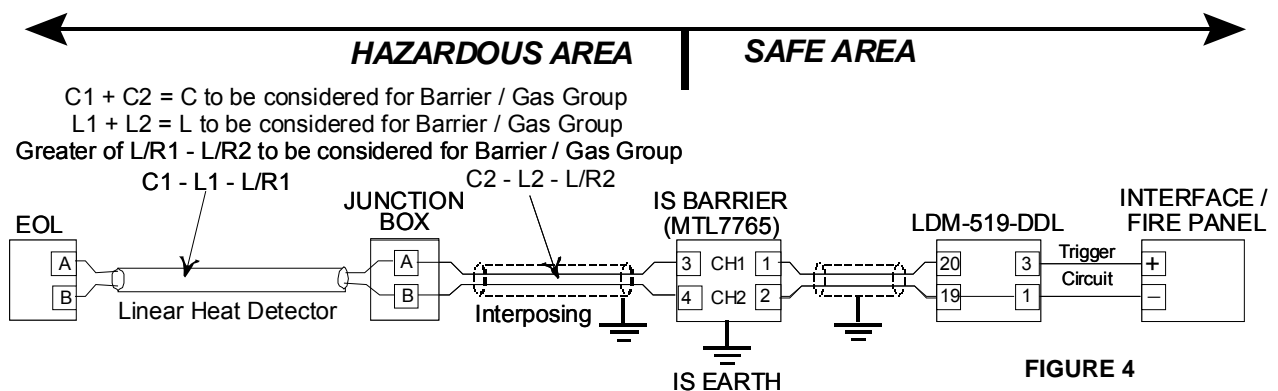

Example : For the above configuration with Group IIC gas and 50m of hazardous area interposing cable specified at : $C/m = 71\text{pF/m}$ $L/m = 0.39\text{uH/m}$ $L/R = 17\text{uH}/\Omega$.

Patol Standard Digital LHDC : $C/m = 120\text{pF/m}$ $L/m = 0.95\text{uH/m}$ $L/R = 5.5\text{uH}/\Omega$.

Both LHDC and Interposing Cable L/R ratios are less than $22\text{uH}/\Omega$.

Available capacitance : $0.58\text{uF} - (71\text{pF} \times 50\text{m}) = 0.5796\text{uF}$: $0.5796\text{uF}/120\text{pF} = 4830\text{m}$

Available inductance : $0.32\text{mH} - (0.39\text{uH} \times 50\text{m}) = 0.3005\text{mH}$: $0.3005\text{mH}/0.95\text{uH} = 316\text{m}$

Inductance is the limiting factor with the maximum permissible length of LHDC = 316m

The LHDC can be arranged to operate via a single channel barrier by employing a 'return to earth' as per Fig.5. Full isolation between earth and Fire System is realised by using the LDM-519-DDL volt free relay contacts.

The maximum permitted hazardous area cable parameters for the MTL7765 for isolated (discrete) channels (no interconnection in hazardous area) are:-

MTL7765	EC Directive 94/9/EC (ATEX / BASEEFA)			FM
	Group IIA	Group IIB	Group IIC	
Isolated Channels				Groups A & B
Capacitance	14 uF	3.55 uF	0.58 uF	0.58 uF
Inductance	14.42 mH	7.22 mH	1.45 mH	1.45 mH
L/R ratio	544 uH/ohm	263 uH/ohm	66 uH/ohm	66 uH/ohm

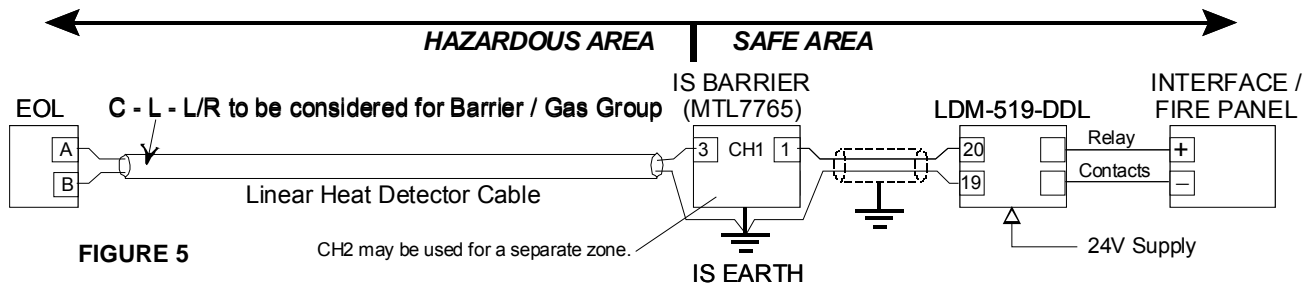

FIGURE 5

Example : For the above configuration with Group IIC gas and no interposing cable.

Patol Standard Digital LHDC : $C/m = 120\text{pF/m}$ $L/m = 0.95\text{uH/m}$ $L/R = 5.5\text{uH}/\Omega$.

The L/R ratio is $(5.5\text{uH}/\Omega)$ less than $66\text{uH}/\Omega$.

Available capacitance : $0.58\text{uF} : 0.58\text{uF}/120\text{pF} = 4833\text{m}$

Available inductance : $1.45\text{mH} : 1.45\text{mH}/0.95\text{uH} = \underline{1526\text{m}}$

Inductance is the limiting factor with the maximum permissible length of LHDC = 1526m

Power Supply Earth Referencing

Aside from the intrinsic safety aspects it is important that the 24 Vdc power supply to the zone monitor, address loop interface, etc. is correctly referenced with respect to the Intrinsically Safe Earth bus in order that the LHDC signal is not affected by zener barrier leakage currents.

Patol produces Analogue zone monitor types with the LHDC signal screen common to both positive and negative supply poles. The LHDC screen should stay within 2V of IS Earth.

LDM-519-LP Has negative screen - Supply negative must be referenced to IS Earth.

LDM-519-SEN-N Has positive screen - Supply positive must be referenced to IS Earth.

For other Zone Monitors refer to appropriate data sheets or contact Patol Limited.

Isolators – Galvanic Barriers

IS isolators/galvanic barriers can be used with Patol Digital LHDC. Measurement Technology Ltd. Models MTL3043 & MTL4061 are recommended by MTL for 'Fire Detector' applications, however the simple 'volt free' nature of the LHDC may make other 4000 series switch monitoring type isolators more suitable in certain applications. Some isolators require a separate power supply.

Consideration must be given to open and short circuit fault monitoring techniques. Specific fire panel specifications should be referenced in conjunction with LHDC characteristics and barrier data sheets to determine most compatible types and configurations.

The above information is a guidance note only.

National / Local Regulations, Standards and Barrier Specifications MUST take Precedence in any system design and implementation.