

SERIES 5000 TYPE 5410 INFRA-RED FIRE & HEAT DETECTORS Conveyor & Transport System Monitoring



Type 5410 Infra-red sensors are part of the Patol 5000 Series of equipment which is specifically designed for the protection of establishments and systems where a movement of materials with a potential fire hazard is a routine occurrence.

The 5000 system employs enhanced Infra-red monitoring technology that enables the detection of hot fire initiating materials, whilst they are being transported, and before they have reached an ember, visible ignition or flame condition.

The 5410 detectors have many applications within industries such as Power Generation, Coal Mining, Process Plant, Road Transportation and Rail Networks and has been specifically designed to both meet the rigors of these environments and to provide the reliability required.

- ◆ **Detection of hazards at temperatures below flame point including both embers and buried hot spots.**
- ◆ **Air purged system for *Dusty* environments with air pressure monitoring.**
- ◆ **Two wire operation - Powered by direct connection to standard fire trigger circuits or addressable loop interfaces - Signalling mode user configurable to simulate smoke & heat detector protocols.**
- ◆ **Patol remote controllers/interfaces available for two wire operation.**
- ◆ **Volt free relay contact output operation selectable as standard.**
- ◆ **Twin high integrity detection circuit channels for maximum reliability.**
- ◆ **Unique reflective cone lensing system provides wide uniform coverage superior to ember/spark detectors.**
- ◆ **Coincidence - *Double Knock* - option for unit detector channels as standard.**
- ◆ **Timed auto reset / coincidence analyser circuit.**
- ◆ **Tuned response - solar blind.**
- ◆ **High degree of ingress protection - IP66.**
- ◆ **Specifically designed for high EMC compliance.**

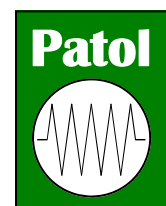

TYPE 5410 INFRA-RED FIRE & HEAT DETECTORS

Principles

The principal of operation is that temperature dependant black body emissions occur for all materials. These emissions range through the infra red spectrum to visible light. Both the wavelength and level of peak energy emission are related to temperature.

The Series 5000 detectors are designed to detect the changes in these emissions that occur when a hot body enters the field of view of the detector.

By the use of both optical filtering and electronic analysis of the various parameters the system is blind to visible light from the sun or local luminaires, whilst being able to detect relatively low temperature material moving through the field of view.

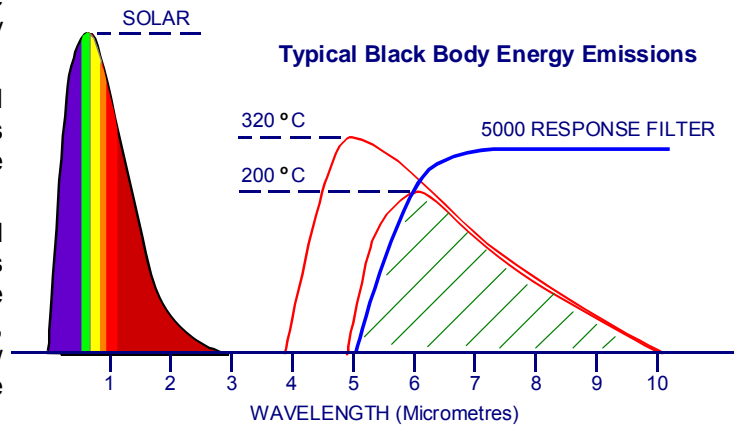

Applications

The 5000 system is most suited to situations where material or equipment that has a fire initiating potential is being moved. For example, the system can detect and prevent a FIRE from being imported into a protected area, as in the case of a burning road or rail vehicle entering a tunnel or building.

In addition the system can monitor for materials in transit, that have not yet reached a flame condition, but have sufficient energy to initiate a fire upon arrival at their destination.

A typical example is in the coal feed systems on power stations where coal on the 'out field stack' may very well smoulder with little adverse effect for long periods of time. However, if imported to the power station it may have devastating effects on conveyor systems, holding hoppers, blending plants, etc.,

- ◆ *Conveyors*
- ◆ *Escalators*
- ◆ *Drying Lines*
- ◆ *Rail Systems*
- ◆ *Food Processing*
- ◆ *Road Tunnels*
- ◆ *Production Lines*
- ◆ *Baggage Handling*
- ◆ *Warehouse Robots*

The System

The type 5410 minimum system comprises two primary elements - the sensor unit and an air supply. The latter is required such that a positive air pressure is maintained at the sensor unit optical lens aperture, thus preventing dust settling on the detector windows. This air purging is essential in dusty environments such as coal conveyors, and is recommended in even relatively clean applications. A series 5000 air purge blower and unit is employed when an 'on site' clean air supply is not available.

The sensor unit is located above or beside the materials transit path (conveyor, roadway, etc.) by means of the adjustable mounting bracket and aligned such that the monitored hazard passes through the sensor's field of view. The distance and angle of the sensor determine the width of the monitored path.

Typically conveyor widths of 1.6 to 4.2 m can be monitored with a sensor mounted 1.0 to 1.5 m above the conveyor at an angle of 0° to 55°.

The air supply is monitored by a pressure switch which on air failure is signalled as a fault status. Alarm (Fire) conditions may be set for double knock operation.

An internal multi-pole switch permits the various configuration selections.

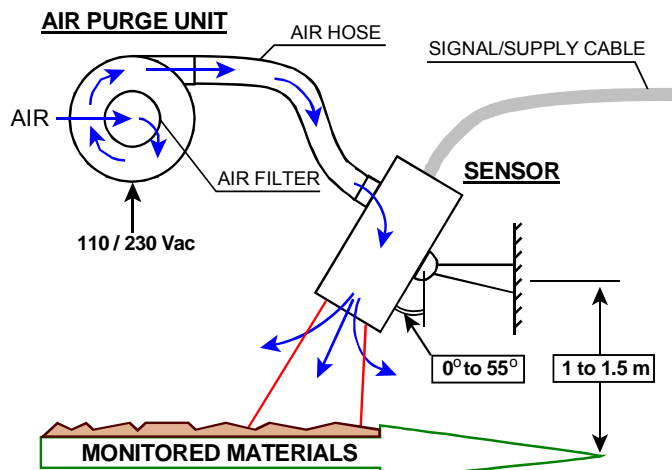

TYPE 5410 INFRA-RED FIRE & HEAT DETECTORS

Sensor Arrangement

A dual detector channel sensing module is located within an ABS housing which is mounted by means of an adjustable bracket permitting alignment in both vertical and horizontal planes. The outer housing is equipped with an air hose spigot. The signal cable enters through glands in both outer housing and inner module and is terminated at screw terminals. The inner module is rated IP66.

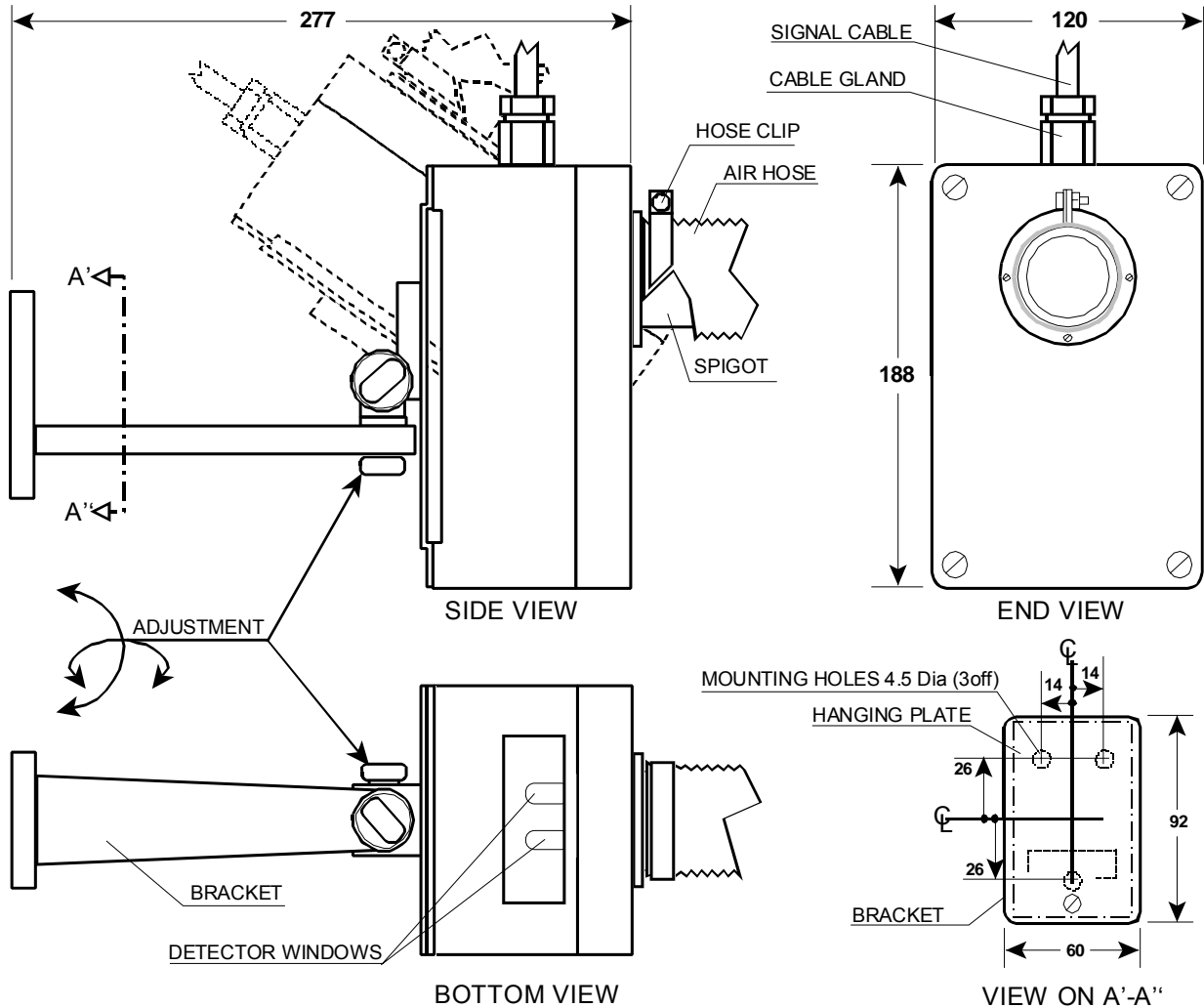

Air Purging

The sensor unit is equipped with a spigot for connection to a flexible hose. If an 'on site' air supply capable of delivering 5.0 ltrs/sec at this connection is not available a Series 5000 Air Purge Unit should be employed. Some units are equipped with an easily removable and washable air filter, however these filters are intended to preserve blower life in *normal* conditions. The blower should either be installed outside the dirty/dusty area or the unit inlet piped to a *clean* air environment. Intermediate rigid ducting is most readily achieved by the use of standard μ PVC pipes and fittings. 2 m of hose is provided with each purge unit for couplings at sensor & blower.

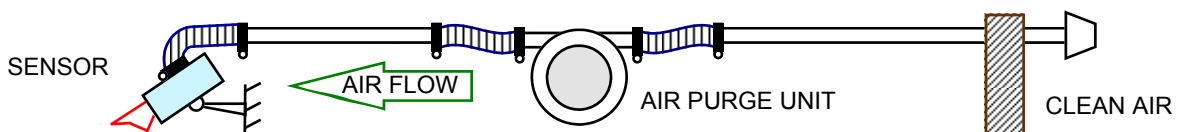

5000 Series Air Purge Units are fan blowers which can be supplied in a variety of configurations. These include both 1 & 3 phase supplies at 110, 230 & 380/440 Vac, a variety of hose/duct connection arrangements, and high capacity units.

TYPE 5410 INFRA-RED FIRE & HEAT DETECTORS

Electrical Configuration

The unit may be user selected to either of two principal operating settings which are referenced as "Relay Mode" and "Low Power Mode" and are described as follows:-

Relay Mode

The unit is equipped with relays which are enabled in this mode.

A 24 Vdc (nom) supply is required to operate the unit (max current 24mA).

The unit's volt free relay contacts are used for signalling of Fire and Fault conditions.

The Fire relay is normally de-energised and energises on an infra-red detection alarm.

The Fault relay is normally energised and de-energises on module regulation failure or supply loss.

Low Power Mode

In this mode the relays are disabled and the unit's quiescent supply current is very low and of a similar level to conventional Smoke and Heat detectors.

By the connection of appropriate resistor values to the sensor's "solid state" outputs the unit will signal Normal, Fire & Fault conditions by line current levels, in a manner that permits the unit to be connected directly to fire control panels via alarm trigger circuits, or to the monitored inputs of addressable loop interface modules.

The unit can also be employed with the two wire connection to a remote Patol signal relay module.

Three typical configurations of supply & signalling operation are:-

Figure 1 shows a simple configuration with the unit directly powered and relays enabled.

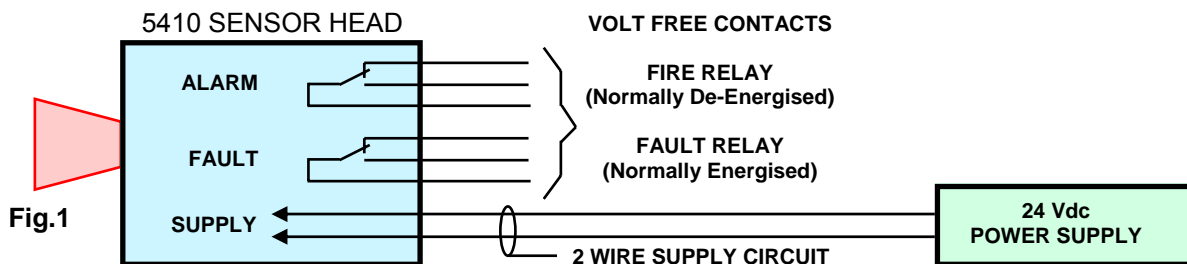

Figure 2 shows the unit directly connected to a fire panel trigger circuit. The unit relays are disabled.

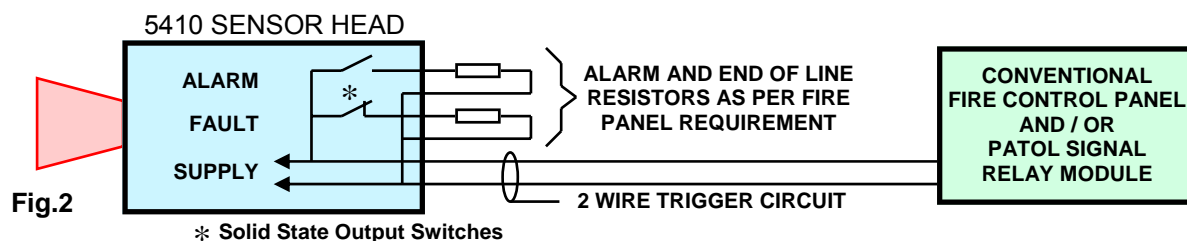
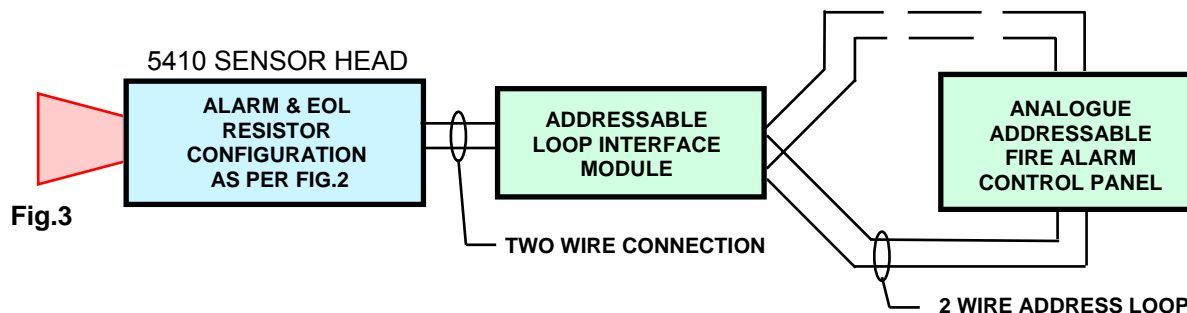

Figure 3 shows a scheme where the unit is both powered from, and signals to, an "Addressable Loop".



TYPE 5410 INFRA-RED FIRE & HEAT DETECTORS

Specification

General

Detectors:- 2 off - Employing reflective cone optical focusing system

Spectral Filter:- 5 - 14 μm

Sensitivity:- 10 - 40 μW

Logic:- Separate electronic channels

Field Of View:- Coincident detector fields
 $+5^\circ/-15^\circ$ on transit path axis
 $+/-38^\circ$ across transit path axis
 See *Coverage Chart* - below

Transit speed:- 0.5 to 6 m/s

Weight:- 1.5 kg

Ingress Rating:- IP66

Temperature :- -20°C to $+70^\circ\text{C}$

Internal / Maintenance Features

Indications:- 2 off - Red LEDs

Controls:- Test PB
Reset PB

SIL Switch :- Sensitivity - 4 level
 (Program 8 way) Latching / Auto Reset
 Auto Reset Timer - 4 settings
 Alarm - One Shot / Coincident

Pressure switch:- Purge Air Monitor - Adjustable

Relay Mode - Direct Supply - Relays Enabled

Supply Voltage:- 20 - 30 Vdc

Supply Current- 9 mA Stand by
24 mA Max / Full Alarm

Alarm Output:- Fire contact - 1 pole C/O
Normally de-energised
Single/Double-knock operation
Rating - 30 Vdc - 500 mA

Monitor Output:- Fault contact - 1 pole C/O
Normally energised
Operates on supply failure
Rating - 30 Vdc - 500 mA

Low Power Mode - Line Current Signalling

Supply Voltage:- 13 - 30 Vdc

Supply Current- Normal - 350 μA - plus EOL*
Fault - 350 μA
Fire - 5 mA plus Alarm Load **

Fault Output:- Solid state switch - Normally On
Fit with trigger circuit EOL* res.
If Supply < 11 Vdc. - EOL Open

Alarm Output:- Solid state switch
Fit with Alarm Load** resistor
Alarm load switched across trigger circuit on fire condition.

Coverage

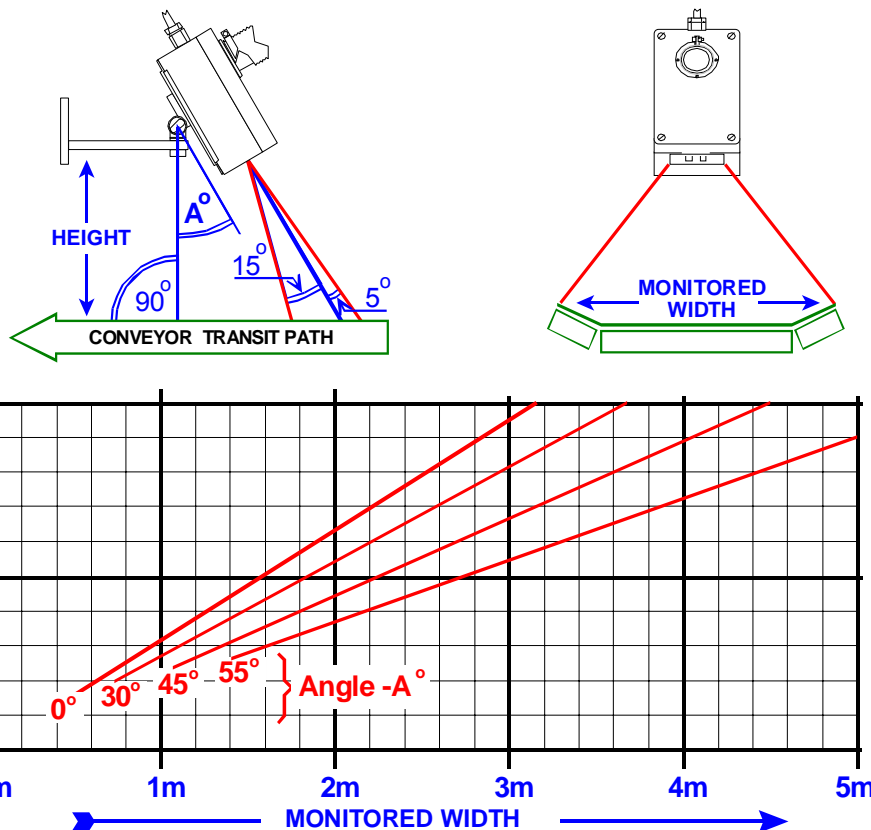

TYPE 5410 INFRA-RED FIRE & HEAT DETECTORS

Connections

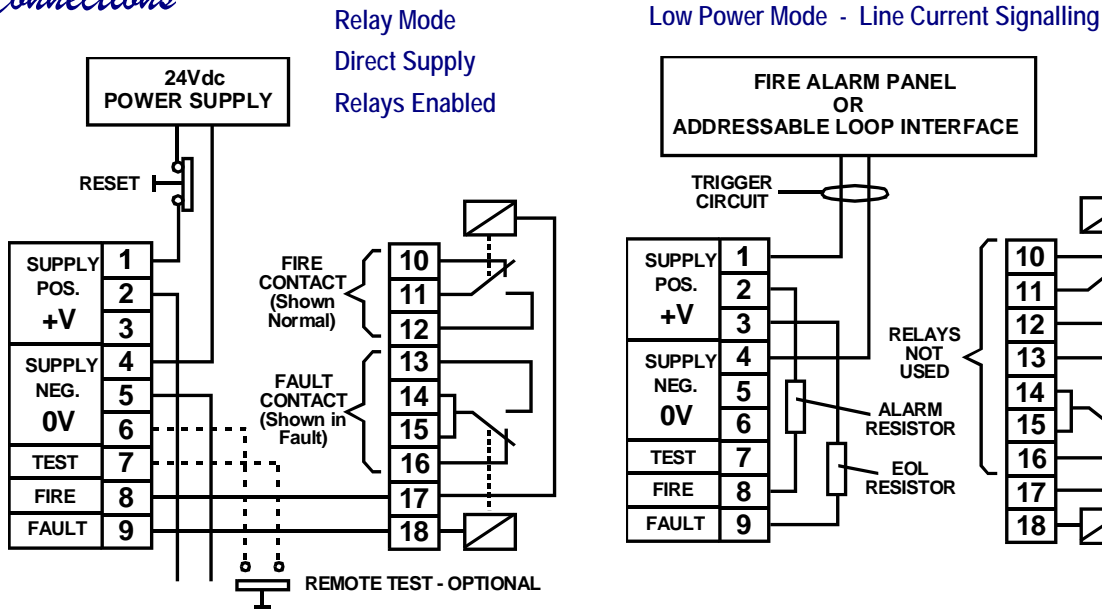

Operational Programmability

An eight pole SIL switch is located within the inner sensor module which programs the unit's operation. Most of the various option features are for special applications, factory test, commissioning or maintenance purpose. A summary of the switch functions is shown in the following tables.

Pole		FUNCTION
1	OFF	Channel LED's only illuminate on alarm
	ON	Channel LED's illuminate before D/K alarm
2	OFF	Double Knock - Coincident Output
	ON	Single Operation - OR - Output
3	OFF	Latching Operation
	ON	Non-latching Operation
4	OFF	Only single detections auto-reset after scan period
	ON	All detections auto-reset after scan period

Pole	AUTO RESET DELAY - SCAN PERIOD							
5	OFF	2.6s	OFF	1.3s	ON	0.9s	ON	0.6s
6	OFF		ON		OFF		ON	
SENSITIVITY (A=Most : D=Least)								
7	OFF	A	OFF	B	ON	C	ON	D
8	OFF		ON		OFF		ON	

Normally there are two "In Service" settings. Special application sheets will define other modes.

SINGLE KNOCK OPERATION : SIL Switch setting for normal "stand alone" detection service.

Operation of <u>either</u> detection channel causes a latched Fire Alarm state. The unit is reset by momentary supply removal.	Pole	1	2	3	4	5	6	7	8
		OFF	ON	OFF	OFF	OFF	ON	User	User

DOUBLE KNOCK OPERATION : SIL Switch setting for normal "stand alone" detection service.

Coincident operation of <u>both</u> detection channels (within scan period) causes a latched Fire Alarm state. The unit is reset by momentary supply removal.	Pole	1	2	3	4	5	6	7	8
		OFF	OFF	OFF	OFF	OFF	ON	User	User



Patol Limited

**Rectory Road, Padworth Common,
Berkshire, United Kingdom. RG7 4JD**
Tel: +44 (0) 118 9701701 email : info@patol.co.uk
Fax: +44 (0) 118 9701700 Web: www.patol.co.uk